

ict

Leonid
Mini Hopper
Installation Guide



International Currency Technologies Corp.

Use of Materials Limitations

International Currency Technologies Corporation (ICT) all rights reserved.

All materials contained are the copyrighted property of ICT.

All trademarks, service marks, and trade names are proprietary to ICT.

ICT reserves the right at all times to disclose or to modify any information as ICT deems necessary to satisfy any applicable law, regulation, legal process or governmental request, or to edit, refuse to post or to remove any information or materials, in whole or in part, in ICT's sole discretion.

Contacts

1. Introduction

1-1. Overview..... 2

1-2. Features..... 2

2. Specifications..... 3

3. Packing List..... 4

4. Dimension..... 5

5. Installation

5-1. Harness Application..... 7

5-2. I/O Circuit..... 13

5-3. Mini Hopper With CPU Board

5-3-1. Mini Hopper Setup..... 18

5-3-2. DIP Switch Setting..... 21

5-3-3. Connection..... 24

5-4. Mini Hopper Without CPU Board

5-4-1. Mini Hopper Setup..... 25

5-4-2. DIP Switch Setting..... 27

5-4-3. Connection..... 27

5-5. Adjustment Coin Dimension..... 28

6. Maintenance..... 31

7. Troubleshooting..... 32

◆ **Appendix_ccTalk Information**

1. Introduction

1-1. Overview

Mini hopper is a coin dispensing unit for one denomination. Users can adjust the coin dimension with different coin payout plates and coin adjustment points. The design of Mini Hopper is easy-operated, trouble-free, and high reliability.

1-2. Features

- Dual sensors, double protections.
- Easy maintenance.
- Easy installation.
- Coin size adjustable.
- Advanced coin low level detection.
- Compact design with enormous capacity.

2. Specifications

General

Dispensing Speed	12V DC: 5~6 coins/second 24V DC: 6~8 coins/second
Interface	Pulse, ICT, Hopper, ccTalk, Red Flag <i>*Note: For ccTalk information, please refer to Appendix.</i>
Counting Method	Dual sensors
Installation	Indoor

Electrical

Power Source	MH-12XXX: 12V DC (11.4~12.6V DC) MH-24XXX: 24V DC (22.8~25.2V DC)
Power Consumption	12V DC: Standby : 0.05A, 0.6W Not loaded: 0.75A, 9W Maximum : 2.5A, 30W 24V DC: Standby : 0.05A, 1.2W Not loaded: 0.45A, 10.8W Maximum : 2.5A, 60W
Operation Environment	Operation Temperature: 5°C~50°C Storage Temperature: -30°C~70°C Humidity: 30%~85%RH(no condensation)

Mechanical

Coin Capacity	Approx. 500 coins
Accessories(Optional)	Extensions: 500 coins, Max. one extension.
Weight	Approx. 0.8kg

Applicable Coin Size**A TYPE**

(Diameter) 22.5mm~28mm
(Thickness) 1.6mm~2.4mm

B TYPE

(Diameter) 20mm~23mm
(Thickness) 1.6mm~2.2mm

C TYPE

(Diameter) 23mm~30mm
(Thickness) 2.5mm~3.3mm

D TYPE

(Diameter) 23mm~30mm
(Thickness) 1.6mm~2.4mm

E TYPE

(Diameter) 17.9mm~19.7mm
(Thickness) 1.3mm~1.8mm

F TYPE

(Diameter) 22.5mm~28mm
(Thickness) 1.0mm~1.5mm

G TYPE

(Diameter) 20mm~23mm
(Thickness) 1.2mm~1.6mm

H TYPE

(Diameter) 28mm~31mm
(Thickness) 2.0mm~2.8mm

3. Packing List

Main

Mini Hopper

Accessory

Harness: Refer to **5-1**

Mini Hopper Installation Guide

4. Dimension

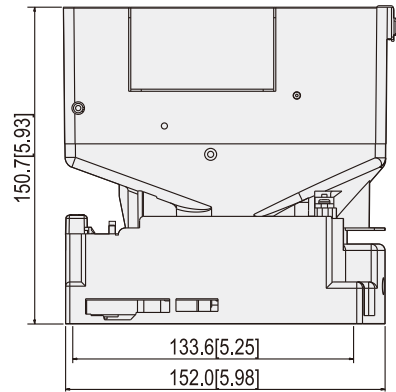
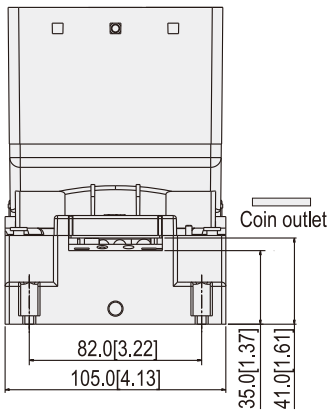
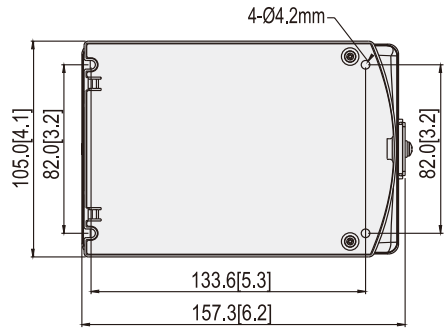
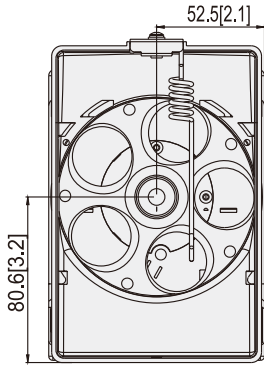

Unit : mm [inch]

4 FIG.01

Extensions: 500 coins (Option)

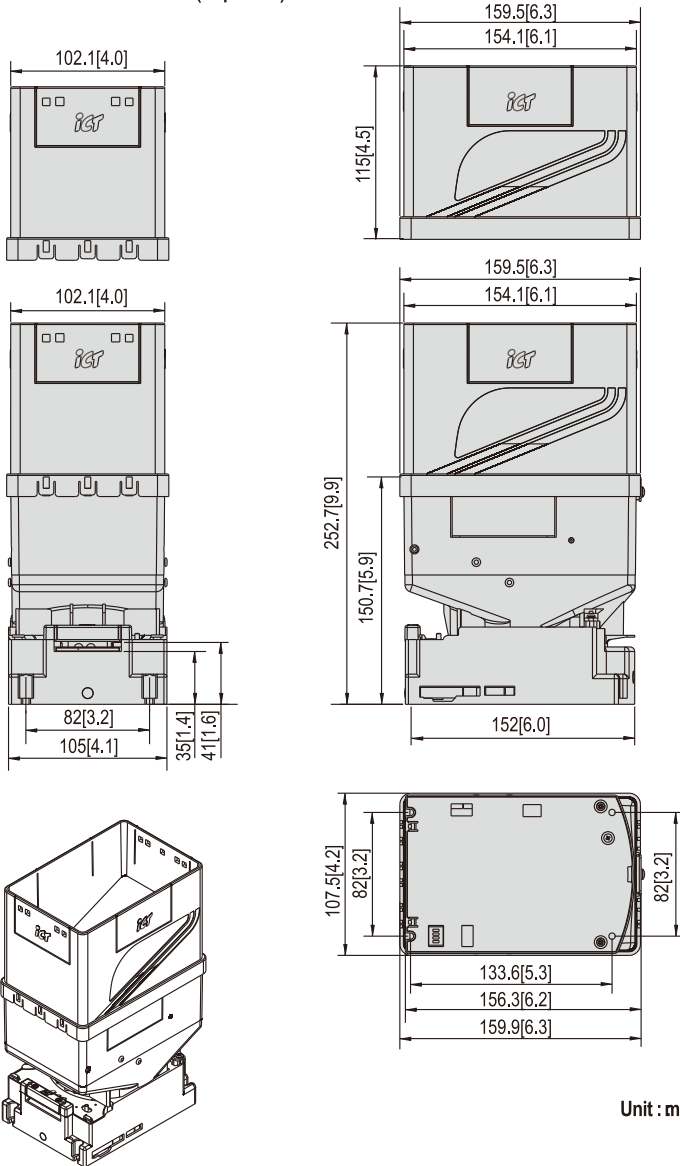

Unit : mm [inch]

1-3 FIG.02

5. Installation

5-1. Harness Application

With CPU Board :

5-1 TABLE 01

Interface	Used Voltage	Usage	Harness	Page
ccTalk	12V DC (MH-12XXX)	Power & *Data Comm.	WEL-RHP02	8
		Power & *Data Comm.	WEL-RHP38	9
		Power & *Data Comm.	CNT-R7025	9
Hopper Mode	24V DC (MH-24XXX)	Power & *Data Comm.	WEL-RHP17	10
Pulse Mode		Power & *Data Comm.	WEL-RHP17	10
ICT Mode		*Data Comm.	WEL-R7U06-2 or 2-BA-R7U06	11
Red Flag		*Data Comm.		11

*Data Comm. : Data Communication.

Without CPU Board :

5-1 TABLE 02

Interface	Used Voltage	Usage	Harness	Page
Hopper Mode	12V DC (MH-12XXX)	Power & *Data Comm.	WEL-RHP17	12
	24V DC (MH-24XXX)			

*Data Comm. : Data Communication.

5-1 FIG.01

Interface	Used Voltage	Usage
ccTalk	12V DC(MH-12XXX) 24V DC(MH-24XXX)	Power & *Data Comm.

WEL-RHP02
(With CPU Board)

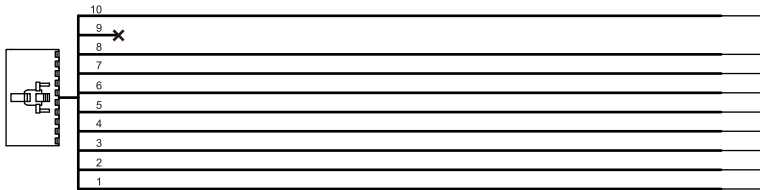

MOLEX42375 10P

PIN 10- GRAY.....RESET	PIN 5- YELLOW.....+12V/+24V DC
PIN 9- Reserved	PIN 4- ORANGE.....+12V/+24V DC
PIN 8- PURPLE.....DATA	PIN 3- RED.....Address select 1
PIN 7- BLUE.....GND	PIN 2- BROWN.....Address select 2
PIN 6- GREEN.....GND	PIN 1- BLACK.....Address select 3

5-1 FIG.02

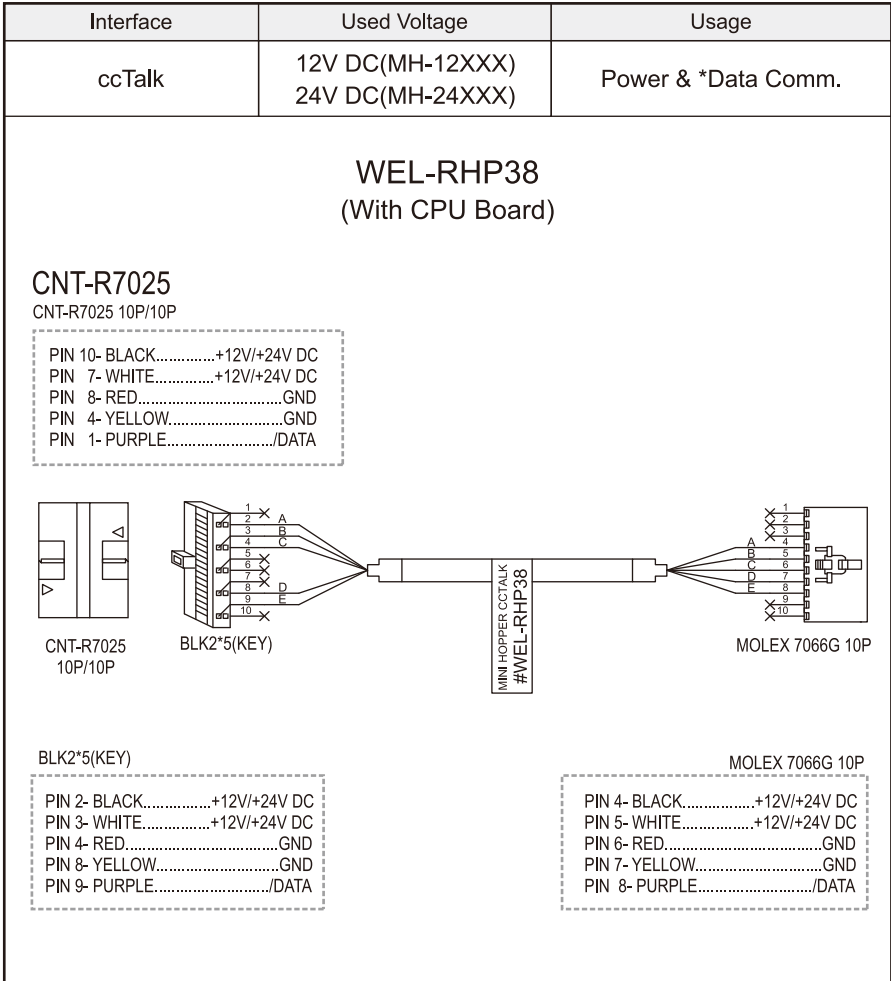

5-1 FIG.03

Interface	Used Voltage	Usage
Hopper Mode	12V DC(MH-12XXX)	Power & *Data Comm.
Pulse Mode	24V DC(MH-24XXX)	

WEL-RHP17
(With CPU Board)

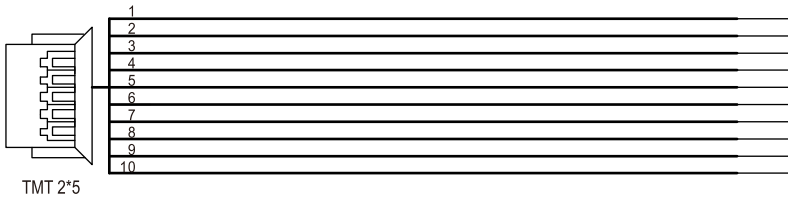

TMT 2*5

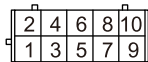

TMT 2*5 BACK VIEW

PIN 1- RED.....+12V/+24V DC (Power)	PIN 6- PURPLE.....COIN_EMPTY_O
PIN 2- BLACK.....Ground(Power)	PIN 7- GRAY.....METER_N_O
PIN 3- YELLOW.....CREDIT RELAY(N.O.)	PIN 8- BLACK.....METER_COM
PIN 4- BLACK.....CREDIT RELAY(Common)	PIN 9- WHITE.....INHIBIT_N_O
PIN 5- BLUE.....PAYOUT_IN	PIN 10- BLACK.....INHIBIT_COM

5-1 FIG.04

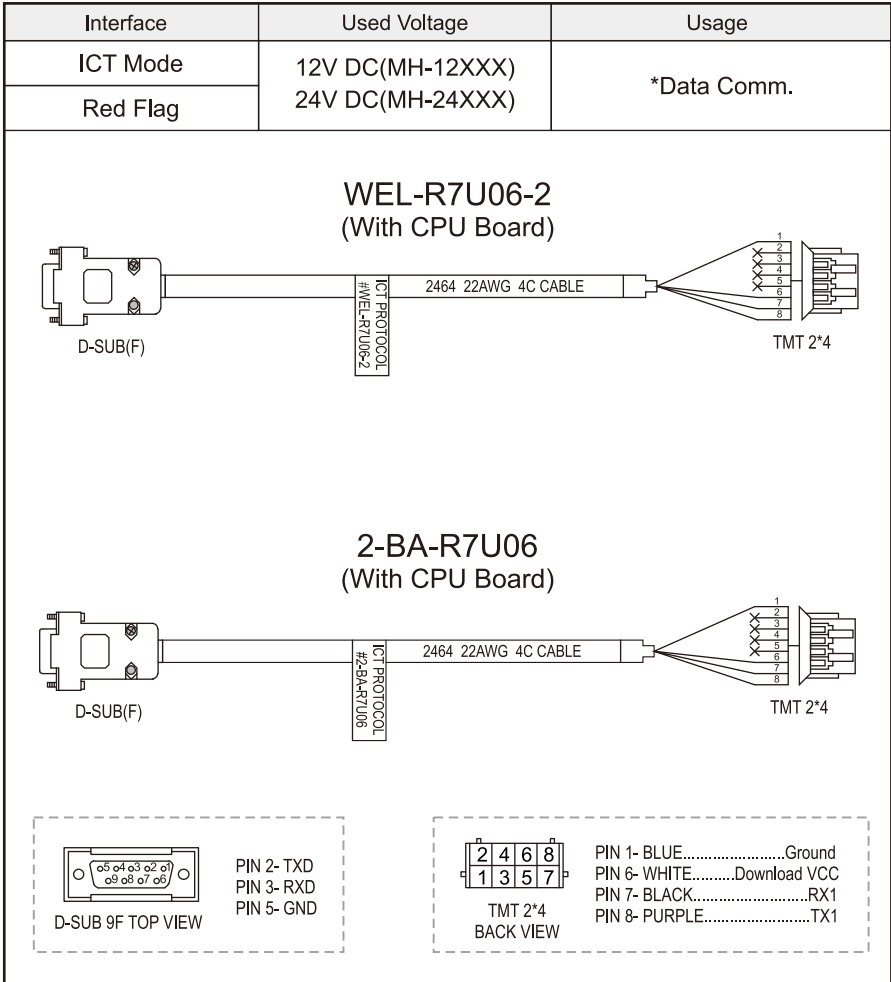

5-1 FIG.05

Interface	Used Voltage	Usage
Hopper Mode	12V DC(MH-12XXX) 24V DC(MH-24XXX)	Power & *Data Comm.

WEL-RHP17
(Without CPU Board)

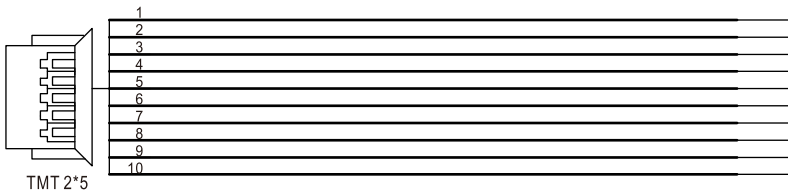

TMT 2*5

2	4	6	8	10
1	3	5	7	9

TMT 2*5 BACK VIEW

PIN 1- RED.....+12V/+24V DC (Power)	PIN 6- PURPLE.....COIN_EMPTY_O
PIN 2- BLACK.....Ground(Power)	PIN 7- GRAY.....TRIGGER_IN+
PIN 3- YELLOW.....CREDIT RELAY(N.O.)	PIN 8- N/A
PIN 4- BLACK.....CREDIT RELAY(Common)	PIN 9- N/A
PIN 5- BLUE.....TRIGGER_IN-	PIN 10- N/A

5-2. I/O Circuit

Hopper & Pulse Interface

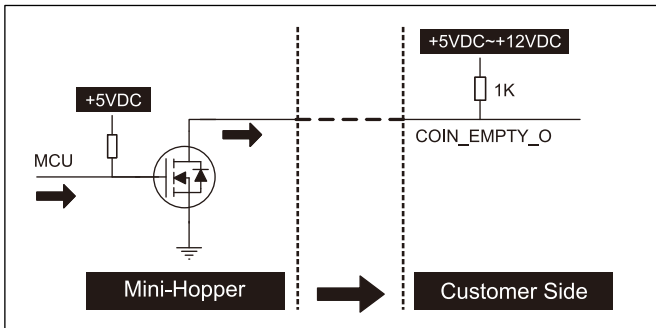
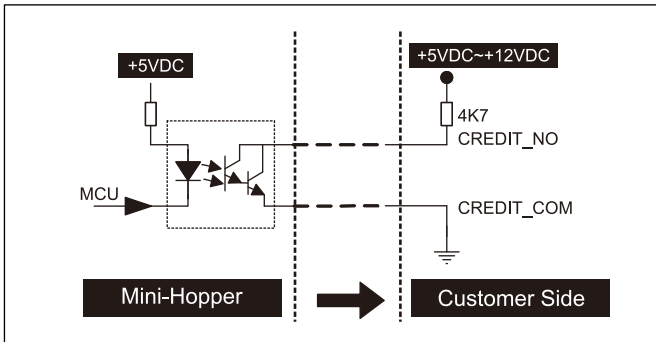
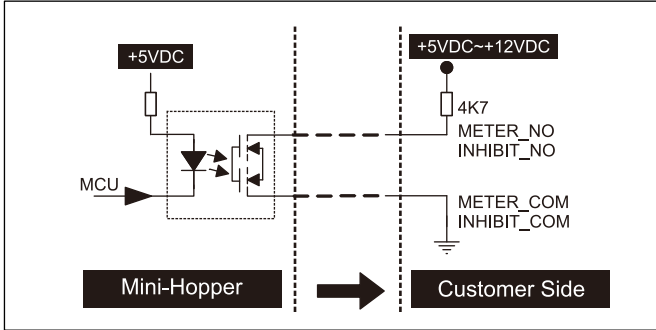

Pulse mode

<Normal>

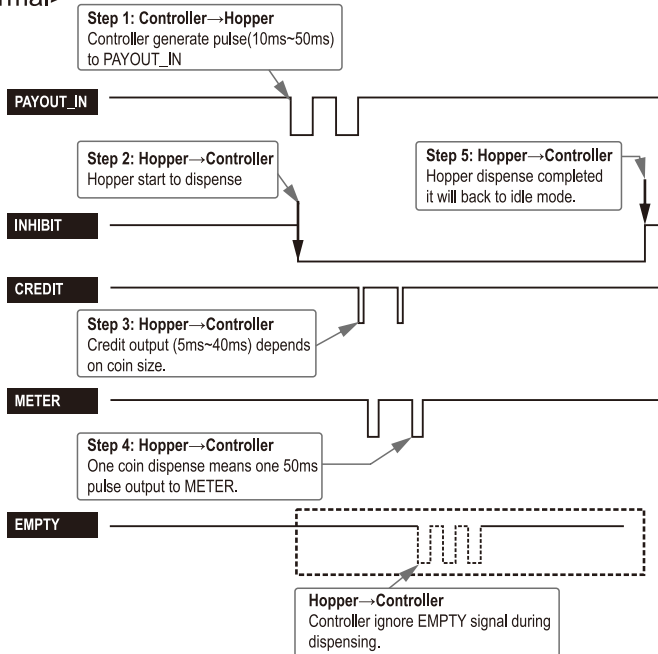

<Error>

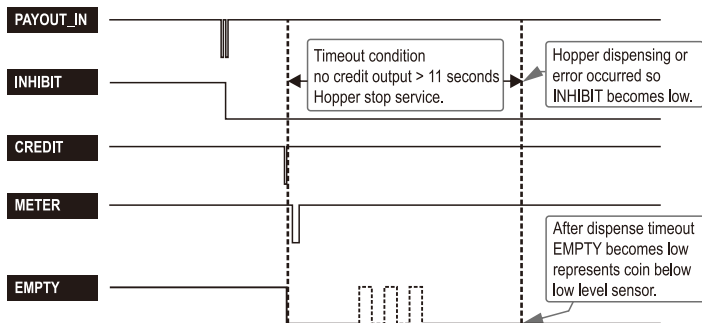

Hopper mode

<Normal>

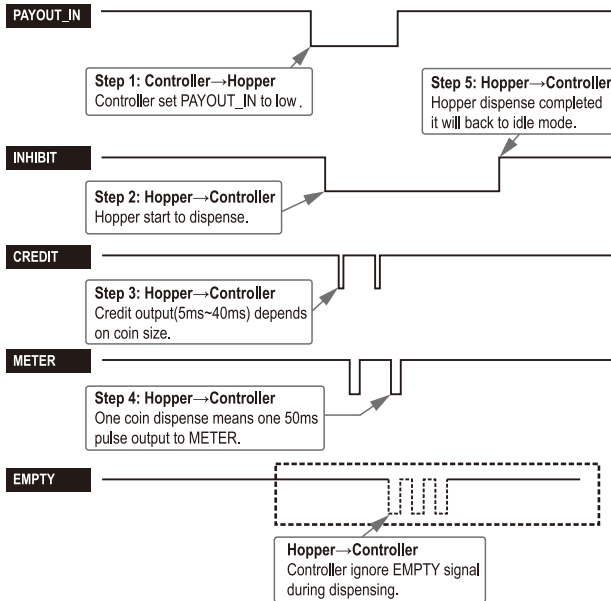

<Error>

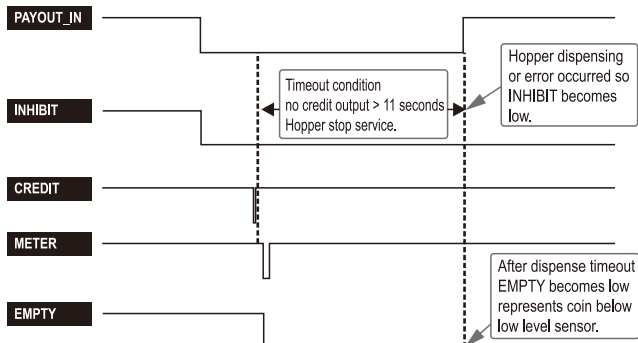

ccTalk Interface.

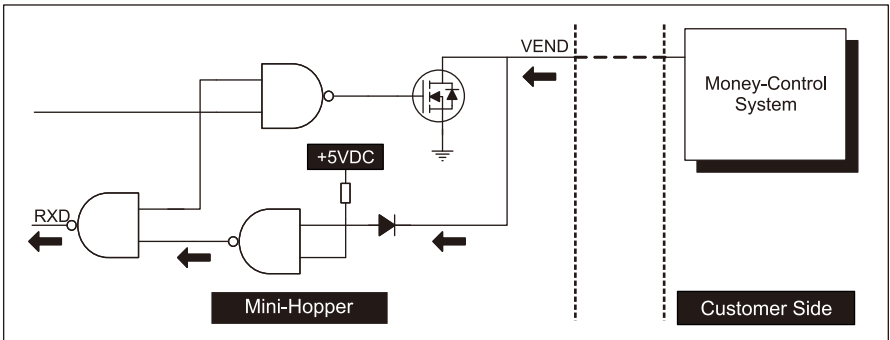
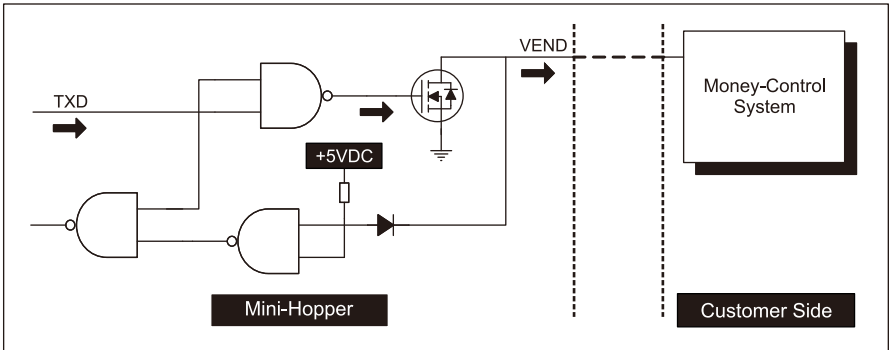

ICT-Protocol & Red Flag Interface.

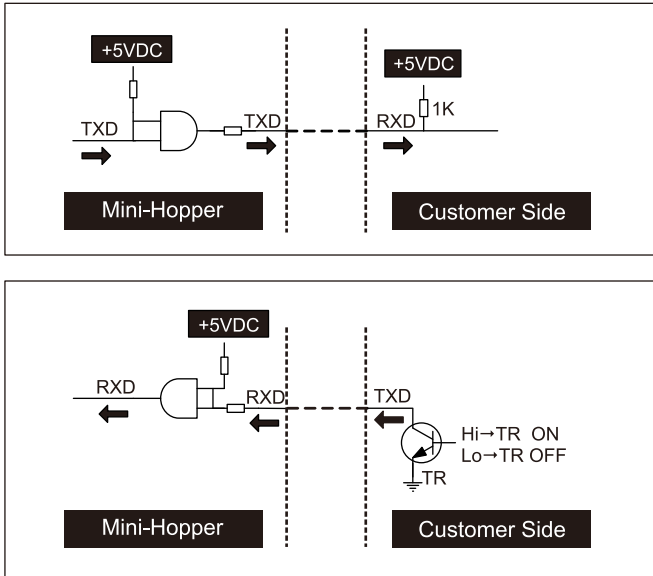

5-3. Mini Hopper With CPU Board

5-3-1. Mini Hopper Setup

(1). For Hopper Mode, Pulse Mode, and ccTalk Mode:

A. Setup DIP Switches which are located at the bottom of Mini Hopper according to interface.

(Please refer to (P.21)

5-3-2. DIP Switch Setup.)

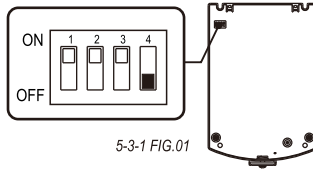

5-3-1 FIG.01

B. Remove the cover by pressing hooks, and then remove coin box.

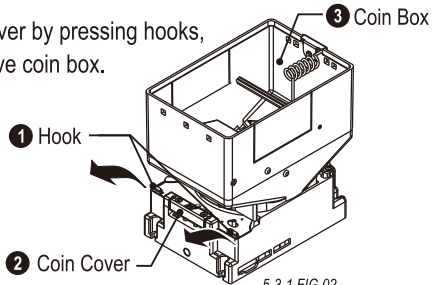

5-3-1 FIG.02

C. Adjust coin dimensions.

(Please refer to (P.28)5-5. Adjustment Coin Dimension Chart.)

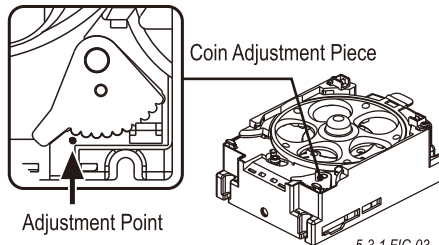

5-3-1 FIG.03

D. Fill coins in the coin box unit, the coins are higher than empty sensor.

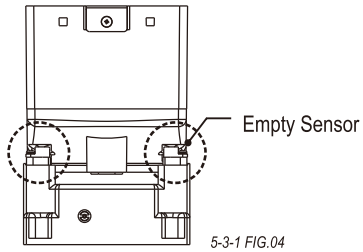

E. Connect the cable to one side of Mini Hopper.
(Please refer to (P.24) 5-3-3. Connection.)

F. Apply power to Mini Hopper, if LED turns
from orange to green, it indicates the
machine is completed setup.

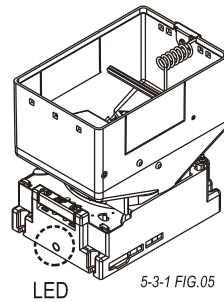

(2). For ICT Mode:

- A. Setup DIP Switches which are located at the bottom of Mini Hopper according to interface.
(Please refer to (P.21) 5-3-2. DIP Switch Setting)

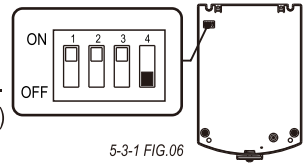

- B. Connect the cable to one side of Mini Hopper.
(Please refer to (P.24) 5-3-3. Connection.)

- C. Download the software(Mini Hopper Tool Kit) from PC through download box (FP-001).



To purchase download box(FP-001) and cables for downloading, please contact ICT.

For software (Mini Hopper Tool Kit) downloading, please go on ICT website: www.ictgroup.com.tw

5-3-2. DIP Switch Setting

(1). For MH-XXXCX

A. ccTalk setup:

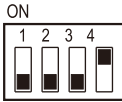

Function	SW1	SW2	SW3	SW4
★ Address 3	OFF	OFF		ON
Address 4	ON	OFF		ON
Address 5	OFF	ON		ON
Address 6	ON	ON		ON
Restore Factory Password(0000)			ON	
System Password			OFF	

(★) Manufacture setting

B. Hopper mode setup:

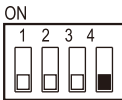

SW1	SW2	SW3	SW4
N/A	N/A	N/A	OFF

(2). For MH-XXXGX

A. ICT mode setup:

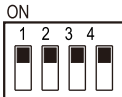

SW1	SW2	SW3	SW4
★ ON	ON	ON	ON

(★) Manufacture setting

Channel setting:

Channel	1	2	3	4	5	6	7	8
Ratio	1	2	5	10	0	0	0	0

Channel	9	10	11	12	13	14	15	16
Ratio	0	0	0	0	0	0	0	0

Channel setting:
(behind factory number 16XXXXXXXXXX)

Channel	1	2	3	4	5	6	7	8
Ratio	1	2	3	4	5	6	7	8

Channel	9	10	11	12	13	14	15	16
Ratio	9	10	500	0	0	0	0	0

B. Pulse mode setup:

ON



Coins/Pulse	SW1	SW2	SW3	SW4
1/1	OFF	OFF	OFF	ON
2/1	ON	OFF	OFF	ON
4/1	OFF	ON	OFF	ON
5/1	ON	ON	OFF	ON
10/1	OFF	OFF	ON	ON
20/1	ON	OFF	ON	ON
50/1	OFF	ON	ON	ON

C. Hopper mode setup:

ON

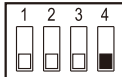

SW1	SW2	SW3	SW4
N/A	N/A	N/A	OFF



Please reset Mini Hopper every time after DIP switch setup.

(3). For MH-XXXFX

A. Red Flag setup:

ON

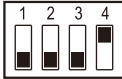

Function	SW1	SW2	SW3	SW4
★ Address 0 9600 baud E/8/1	OFF	OFF	OFF	ON
Address 1 9600 baud E/8/1	ON	OFF	OFF	ON
Address 2 9600 baud E/8/1	OFF	ON	OFF	ON
Address 3 9600 baud E/8/1	ON	ON	OFF	ON
Address 0 19200 baud E/8/1	OFF	OFF	ON	ON
Address 1 19200 baud E/8/1	ON	OFF	ON	ON
Address 2 19200 baud E/8/1	OFF	ON	ON	ON
Address 3 19200 baud E/8/1	ON	ON	ON	ON

(★) Manufacture setting

B. Hopper mode setup:

ON



SW1	SW2	SW3	SW4
OFF	OFF	OFF	OFF

5-3-3. Connection

(1) ccTalk Interface Connector

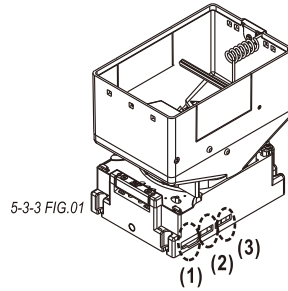
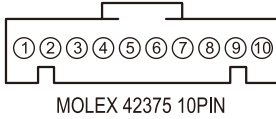

- | | |
|-------------------------|-----------------|
| PIN 1- Address select 3 | PIN 6- Ground |
| PIN 2- Address select 2 | PIN 7- Ground |
| PIN 3- Address select 1 | PIN 8- DATA |
| PIN 4- +12V/+24V DC | PIN 9- Reserved |
| PIN 5- +12V/+24V DC | PIN 10- Reset |

(2) Download and ICT Interface Connector

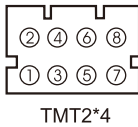

- | | |
|----------------|---------------|
| PIN 1- Ground | PIN 5- /Reset |
| PIN 2- TXD2 | PIN 6- VCC |
| PIN 3- RXD2 | PIN 7- RXD1 |
| PIN 4- Program | PIN 8- TXD1 |

(3) Power and I/O Connector (Hopper Mode or Pulse Mode)

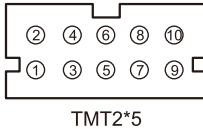

- | | |
|-----------------------------|---------------------|
| PIN 1- +12V/+24V DC(Power) | PIN 6- COIN_EMPTY_O |
| PIN 2- Ground(Power) | PIN 7- METER_N.O |
| PIN 3- CREDIT RELAY(N.O.) | PIN 8- METER_COM |
| PIN 4- CREDIT RELAY(Common) | PIN 9- INHIBIT_N.O |
| PIN 5- PAYOUT_IN | PIN10- INHIBIT_COM |

5-4. Mini Hopper Without CPU Board

5-4-1. Mini Hopper Setup

A. Setup DIP Switches which are located at the bottom of Mini Hopper according to interface.

(Please refer to (P.27) 5-4-2. DIP Switch Setup.)

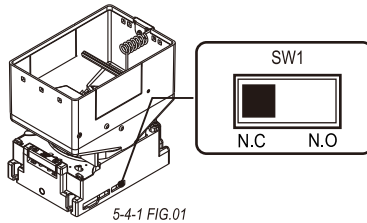

B. Remove the cover by pressing hooks, and then remove coin box.

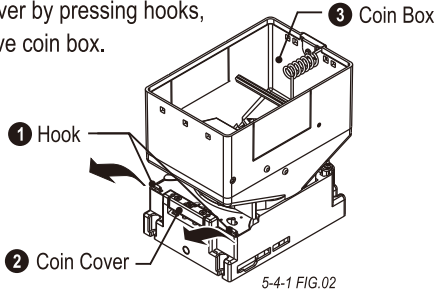

C. Adjust coin dimensions.

(Please refer to (P.28)5-5. Adjustment Coin Dimension Chart.)

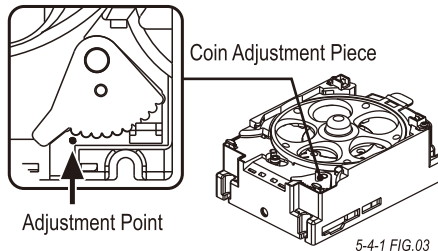

D. Fill coins in the coin box unit, the coins are higher than empty sensor.

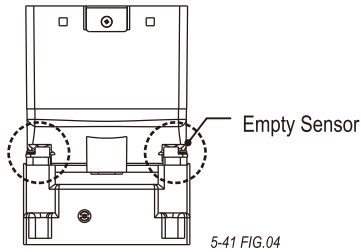

E. Connect the cable to one side of Mini Hopper.
(Please refer to (P.27) 5-4-3. Connection.)

F. Apply power to Mini Hopper, if LED turns from orange to green, it indicates the machine is completed setup.

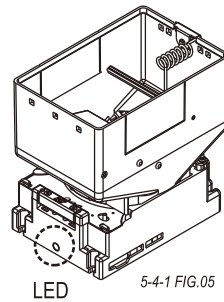

5-4-2. DIP Switch Setting

(1). For MH-XXXXH

A. Credit output function setup:

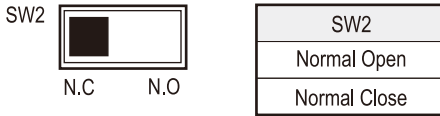

5-4-3. Connection

(1). Power and I/O Connector (Hopper Mode)

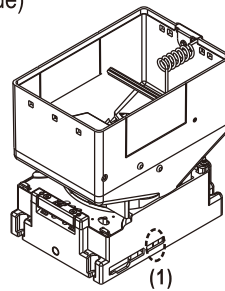
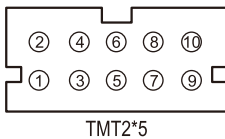



5-4-3 FIG.01

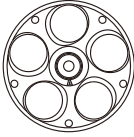
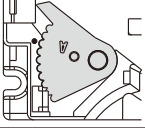
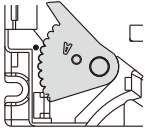
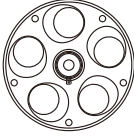
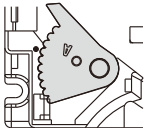
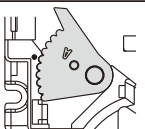

- PIN 1- +12V/+24VDC (Power)
- PIN 2- Ground (Power)
- PIN 3- Credit Relay (N.O.)
- PIN 4- Credit Relay (Common)
- PIN 5- TRIGGER_IN-
- PIN 6- Coin_Empty_Output (Normal Open Active Low)
- PIN 7- TRIGGER_IN+
- PIN 8- N/A
- PIN 9- N/A
- PIN 10- N/A

5-5. Adjustment coin dimension

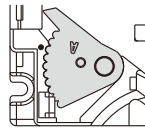
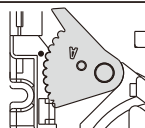
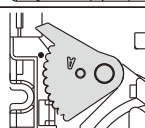
5-5 TABLE 01

Coin Payout Plate	Coin Payout Adjustment	Diameter	22.5mm ≤ 28mm		
A	C1607A-R	thickness	1.6mm ≤ 2.4mm		
 <table border="1" style="margin-left: auto; margin-right: auto;"> <tr> <td>Part number</td> </tr> <tr> <td>A25140-R</td> </tr> </table>	Part number	A25140-R		Diameter	25.5mm ≤ 28mm
	Part number				
	A25140-R				
	thickness	1.6mm ≤ 2.4mm			
	Diameter	22.5mm ≤ 25.5mm			
	thickness	1.6mm ≤ 2.4mm			
Coin Payout Plate	Coin Payout Adjustment	Diameter	20mm ≤ 23mm		
B	C1607A-R	thickness	1.6mm ≤ 2.2mm		
 <table border="1" style="margin-left: auto; margin-right: auto;"> <tr> <td>Part number</td> </tr> <tr> <td>A25920-R</td> </tr> </table>	Part number	A25920-R		Diameter	22.5mm ≤ 23mm
	Part number				
	A25920-R				
	thickness	1.6mm ≤ 2.2mm			
	Diameter	20mm ≤ 22.5mm			
	thickness	1.6mm ≤ 2.2mm			
Coin Payout Plate	Coin Payout Adjustment	Diameter	23mm ≤ 30mm		
C	C1607A-R	thickness	2.5mm ≤ 3.3mm		
 <table border="1" style="margin-left: auto; margin-right: auto;"> <tr> <td>Part number</td> </tr> <tr> <td>A26740-R</td> </tr> </table>	Part number	A26740-R		Diameter	25.5mm ≤ 28mm
	Part number				
	A26740-R				
	thickness	2.5mm ≤ 3.3mm			
		Diameter	23mm ≤ 25.5mm		
		thickness	2.5mm ≤ 3.3mm		
	Diameter	28mm ≤ 30mm			
	thickness	2.5mm ≤ 3.3mm			

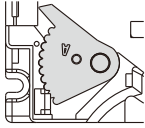
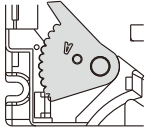
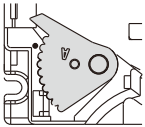
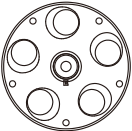
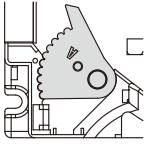
5-5 TABLE 01-1

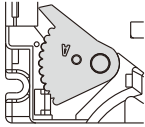
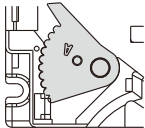
Coin Payout Plate	Coin Payout Adjustment	Diameter	23mm \leq 30mm		
D	C1607A-R	thickness	1.6mm \leq 2.4mm		
 <table border="1" data-bbox="213 676 322 730"> <tr> <td>Part number</td> </tr> <tr> <td>A28730-R</td> </tr> </table>	Part number	A28730-R		Diameter	25.5mm \leq 28mm
	Part number				
	A28730-R				
	thickness	1.6mm \leq 2.4mm			
		Diameter	23mm \leq 25.5mm		
		thickness	1.6mm \leq 2.4mm		
	Diameter	28mm \leq 30mm			
	thickness	1.6mm \leq 2.4mm			
Coin Payout Plate	Coin Payout Adjustment	Diameter	17.9mm \leq 19.7mm		
E	C1607A-R	thickness	1.3mm \leq 1.8mm		
 <table border="1" data-bbox="213 962 322 1016"> <tr> <td>Part number</td> </tr> <tr> <td>A30750-R</td> </tr> </table>	Part number	A30750-R		Diameter	17.9mm \leq 19.7mm
	Part number				
A30750-R					
thickness	1.3mm \leq 1.8mm				
Coin Payout Plate	Coin Payout Adjustment	Diameter	22.5mm \leq 28mm		
F	C1607A-R	thickness	1.0mm \leq 1.5mm		
 <table border="1" data-bbox="213 1303 322 1358"> <tr> <td>Part number</td> </tr> <tr> <td>A31150-R</td> </tr> </table>	Part number	A31150-R		Diameter	25.5mm \leq 28mm
	Part number				
	A31150-R				
	thickness	1.0mm \leq 1.5mm			
	Diameter	22.5mm \leq 25.5mm			
	thickness	1.0mm \leq 1.5mm			

5-5 TABLE 01-2

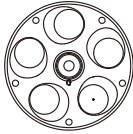
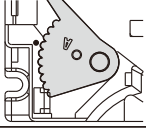
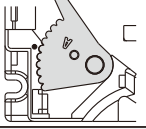
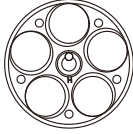
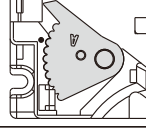
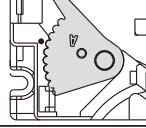
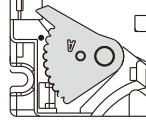
Coin Payout Plate	Coin Payout Adjustment	Diameter	20mm \leq 23mm		
G	C1607A-R	Thickness	1.2mm \leq 1.6mm		
 <table border="1" style="margin-left: auto; margin-right: auto;"> <tr> <td>Part number</td> </tr> <tr> <td>A43910-R</td> </tr> </table>	Part number	A43910-R		Diameter	22.5mm \leq 23mm
	Part number				
	A43910-R				
	Thickness	1.2mm \leq 1.6mm			
		Diameter	20mm \leq 22.5mm		
		Thickness	1.2mm \leq 1.6mm		
Coin Payout Plate	Coin Payout Adjustment	Diameter	28mm \leq 31mm		
H	C1607A-R	thickness	2.0mm \leq 2.8mm		
 <table border="1" style="margin-left: auto; margin-right: auto;"> <tr> <td>Part number</td> </tr> <tr> <td>A46300-R</td> </tr> </table>	Part number	A46300-R		Diameter	25.5mm \leq 28mm
	Part number				
	A46300-R				
	thickness	2.0mm \leq 2.8mm			
			Diameter	23mm \leq 25.5mm	
			thickness	2.0mm \leq 2.8mm	
		Diameter	28mm \leq 31mm		
		thickness	2.0mm \leq 2.8mm		

6. Maintenance

To make sure the Mini Hopper always works smoothly, we suggest you clean the internal parts of Mini Hopper regularly.



Please make sure Mini Hopper turns OFF before cleaning.

To clean the internal parts:

1. Remove the coin box.
2. Use a dry, soft cloth, or brush to clean internal parts and coin path.
3. Use a dry, soft cloth, or towel to clean the coin box

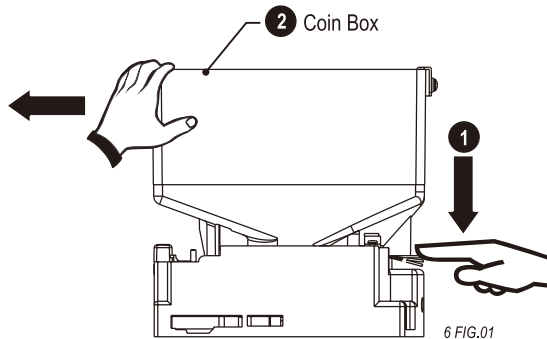



Maintenance Notice
(Any improper maintenance will result invalid warranty.)

Recommended	Mild, non-abrasive, soap water.
DO NOT USE	Organic solvent , Alcohol, Volatile liquid.

7. Troubleshooting

Flashes	Status	Corrective actions
1	1. Incorrect voltage 2. Coin jammed 3. Motor problem	1. Make sure the voltage is applied to Mini Hopper. 2. Clockwise turn the wheel which is in the back of Mini Hopper to remove the jammed coin and check the shaft-block.
2	Insufficient coins	Refill coins or Rester hopper.
3	Double count detect	1. Re-adjust coin size and shaft. 2. Check the control signal refer to 5-2(P13). (After last credit signal output then PAYOUT_IN signal must stop in 12ms other wise may cause coin leak out.)
5	Prism sensor error	Inspect for foreign objects on prism sensor or jammed coins. (as 7 FIG.02)
6	Shaft sensor error	

The diagram shows the internal components of the Mini Hopper. On the left, a circuit board is populated with several sensors: a Shaft Sensor, a Light Gate Sensor, and a Prism Sensor. To the right, an Empty Sensor is connected to the board. A separate view on the right shows the Mini Hopper housing with a dashed line indicating the location of the Wheel, which is a circular component at the back of the device.

! If the errors can not be solved after corrective actions or happen again, please contact ICT for technical support.

◆ **ccTalk Information**

Manufacturer ID: ICT

Equipment Category ID: Payout

Product Code: MH-125/ 245

Build Code: Standard

Serial Number: Default as 1 2 3 4 5 6 7 8

Software Revision: Software Revision label locates in the bottom of Mini Hopper.

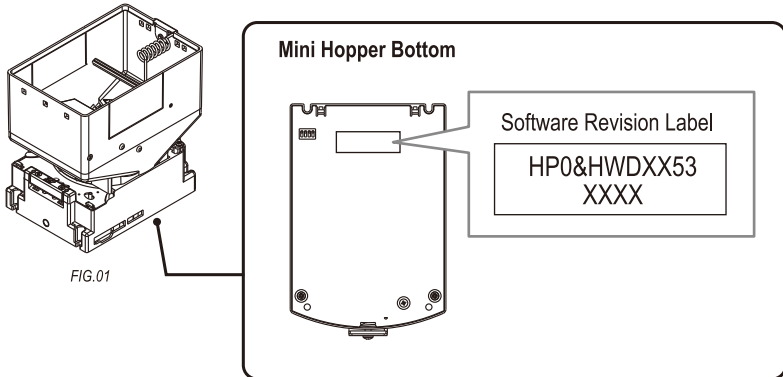

Please contact ICT for more information.

ict Taiwan

International Currency Technologies Corporation

No.28, Ln. 15, Sec. 6, Minquan E. Rd., Neihu Dist., Taipei City 114, Taiwan

sales@ictgroup.com.tw (For Sales)

fae@ictgroup.com.tw (For Customer Service)

Website: www.ictgroup.com.tw

