



Bill Acceptor

# A6E/V6E Series

Installation Guide

International Currency Technologies Corp.

## ***Use of Materials Limitations***

International Currency Technologies Corporation (ICT) all rights reserved.

All materials contained are the copyrighted property of ICT.

All trademarks, service marks, and trade names are proprietary to ICT.

ICT reserves the right at all times to disclose or to modify any information as ICT deems necessary to satisfy any applicable law, regulation, legal process or governmental request, or to edit, refuse to post or to remove any information or materials, in whole or in part, in ICT's sole discretion.

## Contents

1. Introduction	
1-1. Overview .....	2
1-2. Features .....	2
2. Specifications .....	2
3. Packing List .....	3
4. Dimension .....	4
4-1. Bezel Styles .....	5
5. Installation	
5-1. Harness Application .....	8
5-1-1. I/O Circuit .....	17
5-2. DIP Switch Setting .....	20
5-3. Firmware Download and Upgrade .....	20
6. Maintenance .....	21
7. Troubleshooting .....	22

# 1. Introduction

## 1-1. Overview

A6E/V6E Series is a bill acceptor which features not only high-security module with bill box but also outstanding recognition, acceptance rate up to 96% or even greater.

## 1-2. Features

- Four way bill insertion acceptance.
- Auto-calibrating.
- Numerous interfaces available.
- Easily Install & Maintain.

# 2. Specifications

### **General**

Acceptance Rate	96 % or greater
Bill Insertion	Four way acceptable
Transaction Speed	Approx. 3 seconds to stack
Interface	<b>A6E</b> STD Pulse, 5V ENABLE, ICT Protocol
	<b>V6E</b> MDB

### **Electrical**

Power Source	<b>A6E</b> 12V DC(11.4~12.6V DC) 117V AC(105.3~128.7V AC)
	<b>V6E</b> 24V/34V DC(20V~42.5V DC)

Power Consumption	<b>A6E</b> 12V DC	Standby : 0.3A, 4W Operation: 0.9A, 11W Maximum: 2.6A, 32W
	117V AC	Standby : 0.06A, 7W Operation: 0.112A, 14W Maximum: 0.4A, 47W
	<b>V6E</b> 24V/34V DC	Standby : 0.15A, 6W Operation: 0.4A, 14W Maximum: 1.35A, 46W
Operation Environment	Operation Temperature: 0°C~55°C Storage Temperature : -30°C~70°C Humidity: 30%~85% RH(no condensation)	

### ***Mechanical***

Bill Width Accepted	60~67 mm
Bill Capacity	Approx. 100 bills( 40~ 140) 300 bills( 200~ 300) 500 bills( 300~ 500) 550 bills( 440~ 640) 800 bills( 750~ 850) 1000 bills(1000~1140)
Weight	Approx. 2kg(shipping)
Installation	Indoor

## **3. Packing List**

Main	Bill Acceptor
Accessory	Harnesses: Refer to 5-1 A6E/V6E Installation Guide A6E/V6E Switches Setting Guide

## 4. Dimension

### Vertical

4 FIG. 01

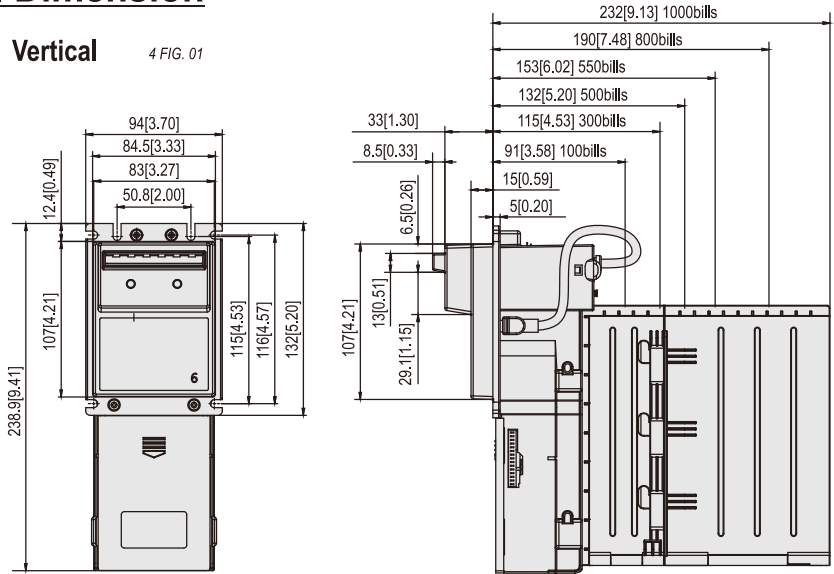

Unit : mm [inch]

### Horizontal

4 FIG. 02

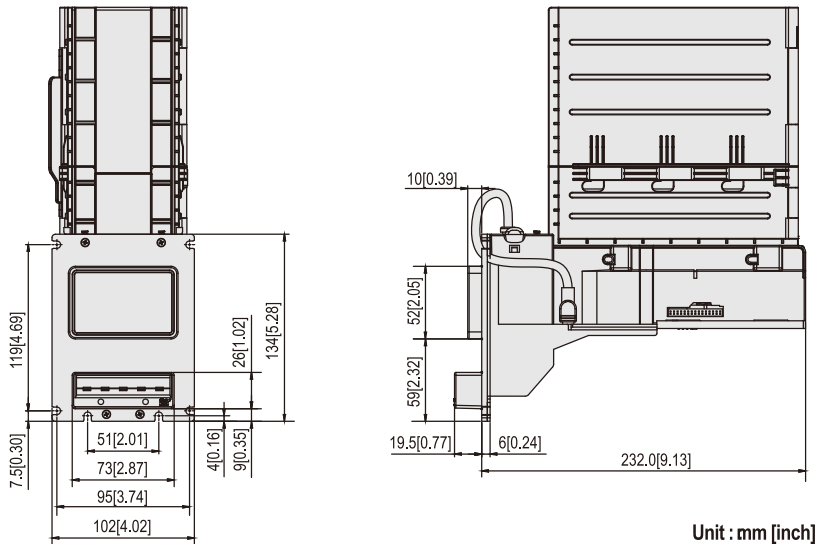

Unit : mm [inch]

## 4-1. Bezel Styles

### Standard bezel

Part Number: 3RMB-FAC01001

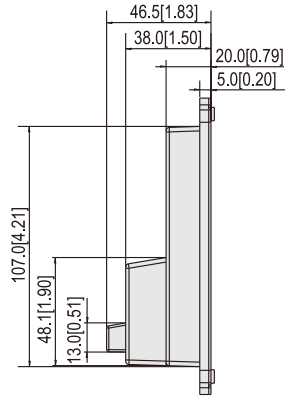
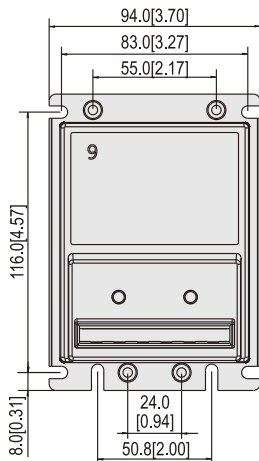

Unit : mm [inch]

4-1 FIG.01

### Fitted bezel

Part Number: 3RMB-FAC02000

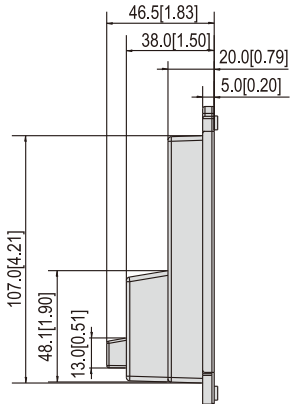
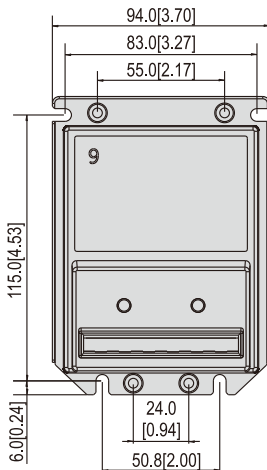

Unit : mm [inch]

4-1 FIG.02

**Anti-coin Bezel**

Part Number: 3RMB-FAC16002

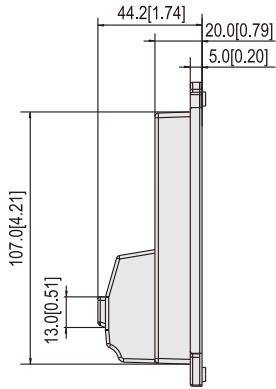
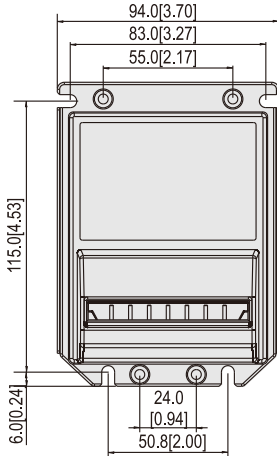

Unit : mm [inch]

4-1 FIG.03

**Horizontal Bezel**

Part Number: 3RMB-FAC10000

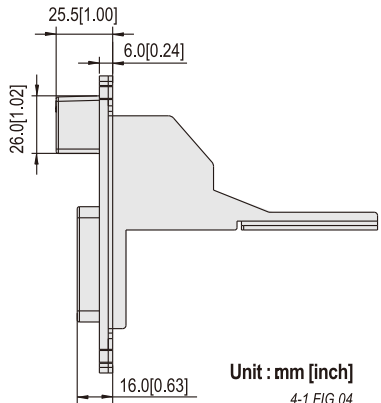
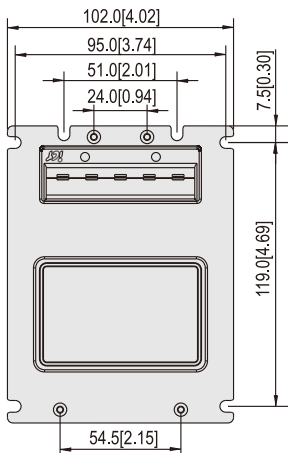

Unit : mm [inch]

4-1 FIG.04

For VFM bezel

Part Number: 3RMB-FAC23000

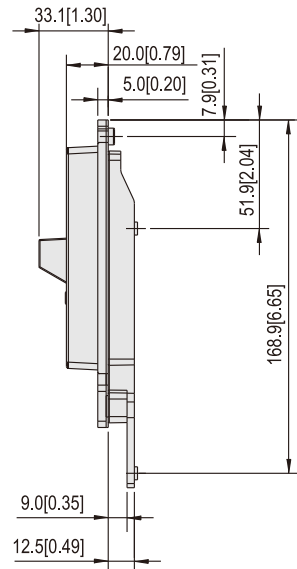
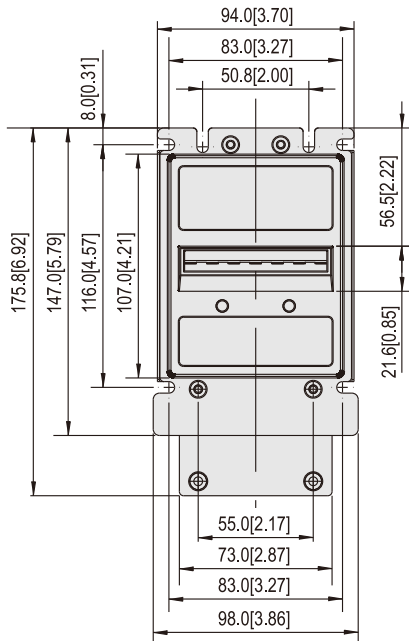
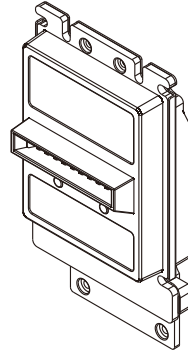
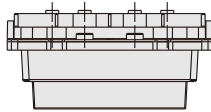

Unit : mm [inch]

4-1 FIG.05

## 5. Installation

### 5-1. Harness Application

5-1 TABLE 01

Model	Interface	Used Voltage	Usage	Harness	Page
A6E	STD Pulse	12V DC	Power & *Data Comm.	WEL-RM044	9
			Extension Wire	CU-R961-1	10
		117V AC	Power & *Data Comm.	WEL-RM045	11
			Extension Wire	WEL-RM012	12
	ICT Protocol (RS232)	12V DC	Power	WEL-RM044	9
			Extension Wire	CU-R961-1	10
			*Data Comm.	WEL-RV706-1 or 2-BA-RV706	15
		117V AC	Power	WEL-RM045	11
			Extension Wire	WEL-RM012	12
			*Data Comm.	WEL-RV706-1 or 2-BA-RV706	15
	5V Enable	117V AC	Power & *Data Comm.	WEL-RM047	13
			Extension Wire	WEL-RM018	14
	V6E	MDB	24V/34V DC	Power & *Data Comm.	WEL-RM006

\*Data Comm. : Data Communication.

5-1 FIG.01

Interface	Used Voltage	Usage
STD Pulse	12V DC	Power & *Data Comm.
ICT Protocol (RS232)	12V DC	Power

### WEL-RM044

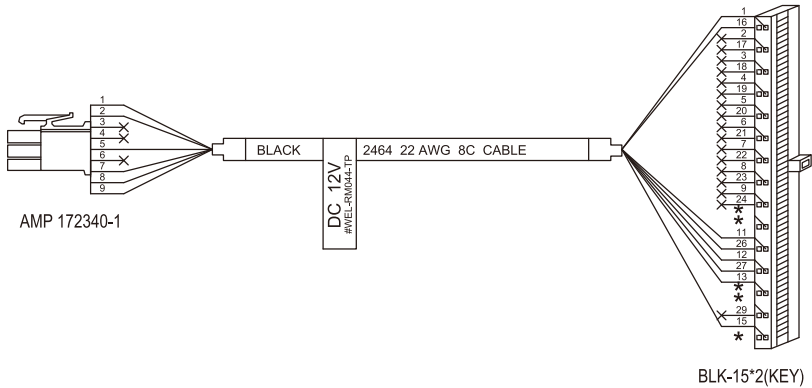



  
 AMP 172340-1  
 BACK VIEW

PIN 1- YELLOW.....	..INHIBIT-
PIN 2- GREEN.....	..INHIBIT+
PIN 5- RED.....	..12V DC
PIN 5- BLACK.....	..ENABLE+
PIN 7- BLUE.....	..CREDIT_RELAY_N.O.
PIN 8- PURPLE.....	..CREDIT_RELAY_COM
PIN 9- WHITE.....	..ENABLE-
PIN 9- BROWN.....	..GND

PIN 1- RED.....	..12VDC
PIN 11- BLUE.....	..CREDIT_RELAY_N.O.
PIN 12- WHITE.....	..ENABLE-
PIN 13- YELLOW.....	..INHIBIT-
PIN 15- GREEN.....	..INHIBIT+
PIN 16- BROWN.....	..GND
PIN 26- PURPLE.....	..CREDIT_RELAY_COM
PIN 27- BLACK.....	..ENABLE+

Interface	Used Voltage	Usage
STD Pulse	12V DC	Extension Wire for WEL-RM044
ICT Protocol (RS232)	12V DC	Extension Wire for WEL-RM044

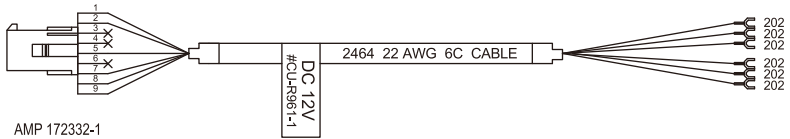
CU-R961-1



AMP 172332-1

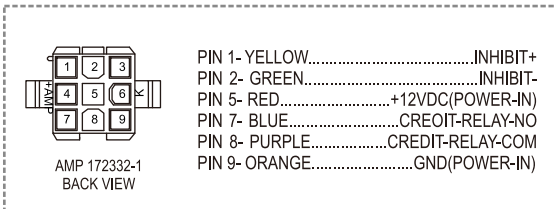

5-1 FIG.03

Interface	Used Voltage	Usage
STD Pulse	117V AC	Power & *Data Comm.
ICT Protocol (RS232 )	117V AC	Power

### WEL-RM045

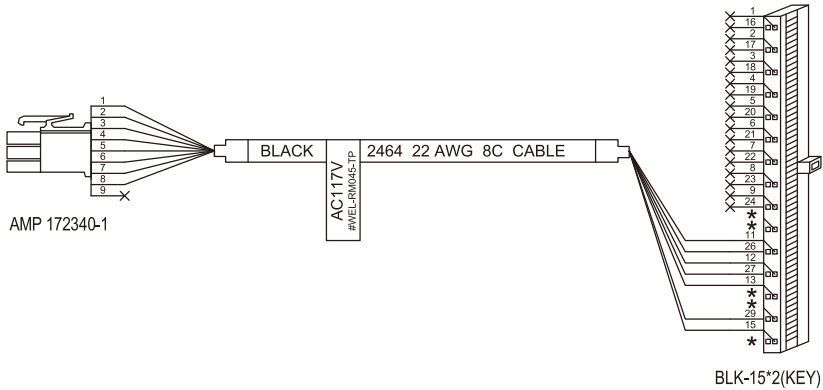

AMP 172340-1  
BACK VIEW

PIN 1- YELLOW.....NEUTRAL\_INHIBIT  
 PIN 2- RED.....NEUTRAL\_ENABLE  
 PIN 3- BROWN.....HOT\_ENABLE  
 PIN 4- BLACK.....115VAC\_HOT  
 PIN 5- GREEN.....RESERVE  
 PIN 6- WHITE.....115VAC\_NEUTRAL  
 PIN 7- BLUE.....CREDIT\_RELAY\_N.O.  
 PIN 8- PURPLE.....CREDIT\_RELAY\_COM

PIN 11- BLUE.....CREDIT\_RELAY\_N.O.  
 PIN 12- RED.....NEUTRAL\_ENABLE  
 PIN 13- YELLOW.....NEUTRAL\_INHIBIT  
 PIN 15- BLACK.....115VAC\_HOT  
 PIN 26- PURPLE.....CREDIT\_RELAY\_COM  
 PIN 27- BROWN.....HOT\_ENABLE  
 PIN 29- WHITE.....115VAC\_NEUTRAL

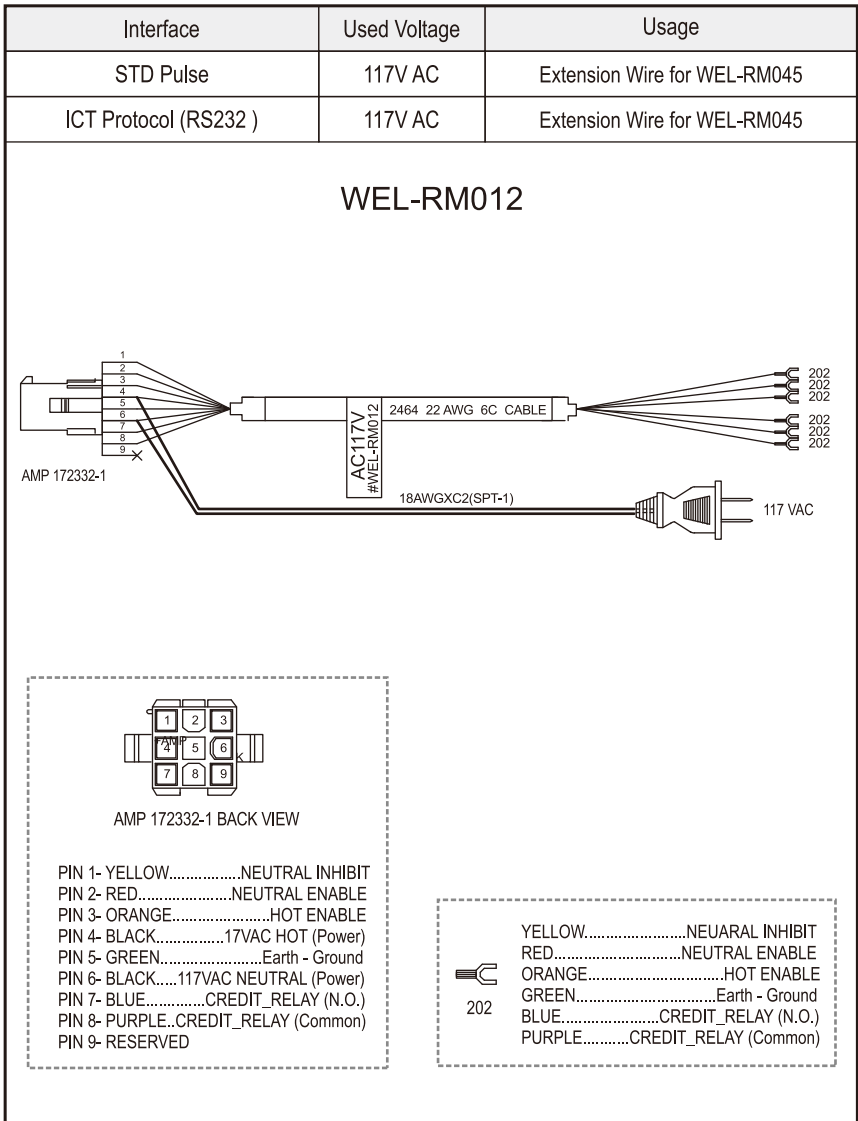

5-1 FIG.05

Interface	Used Voltage	Usage
5V Enable	117V AC	Power & *Data Comm.

### WEL-RM047

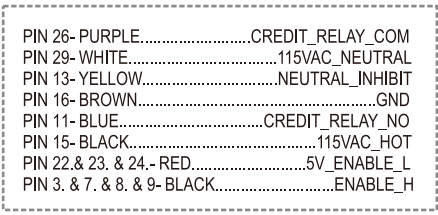
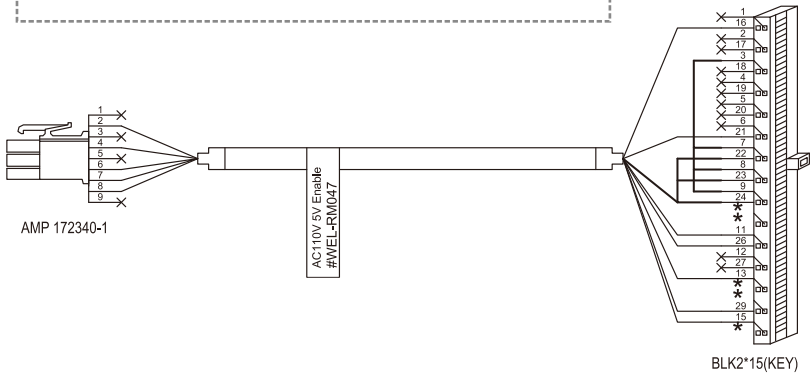
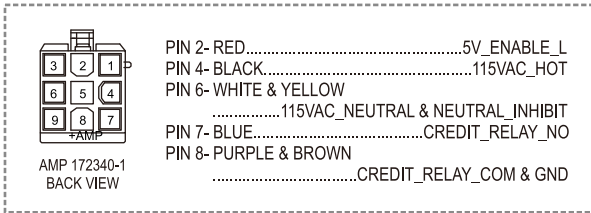

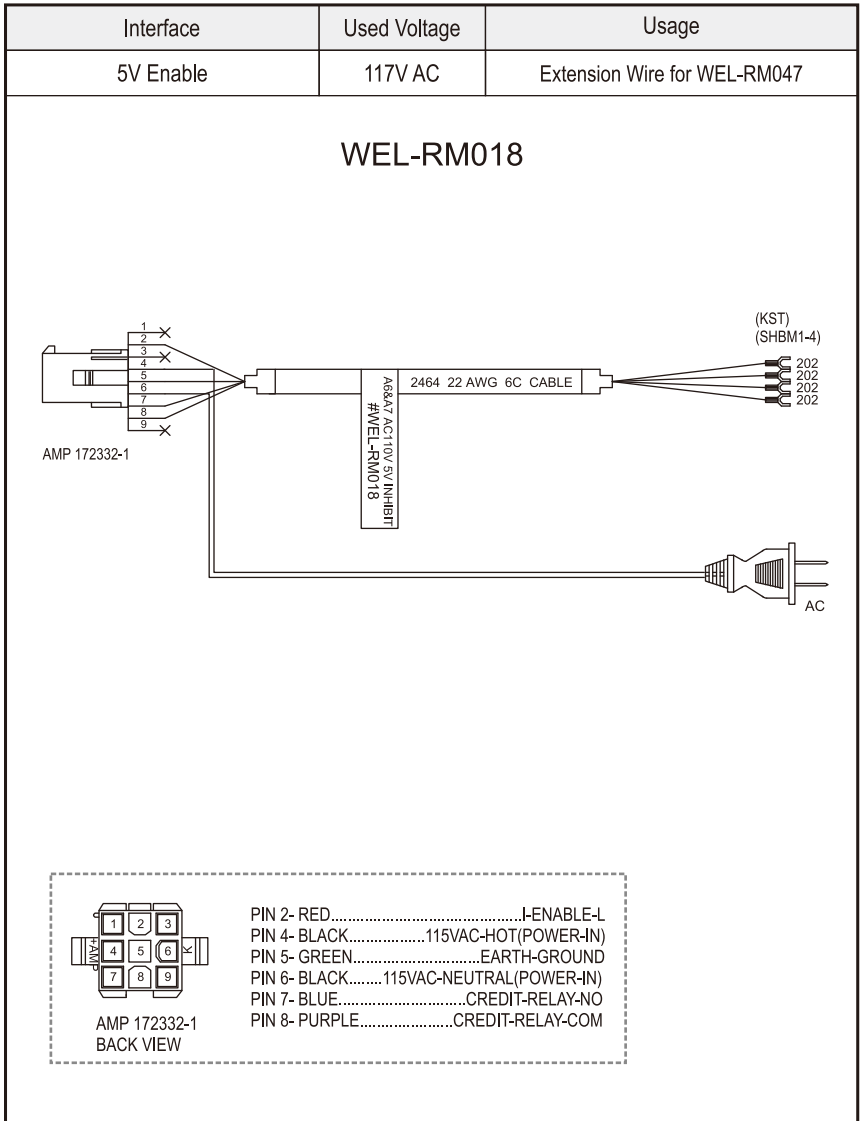

5-1 FIG.07

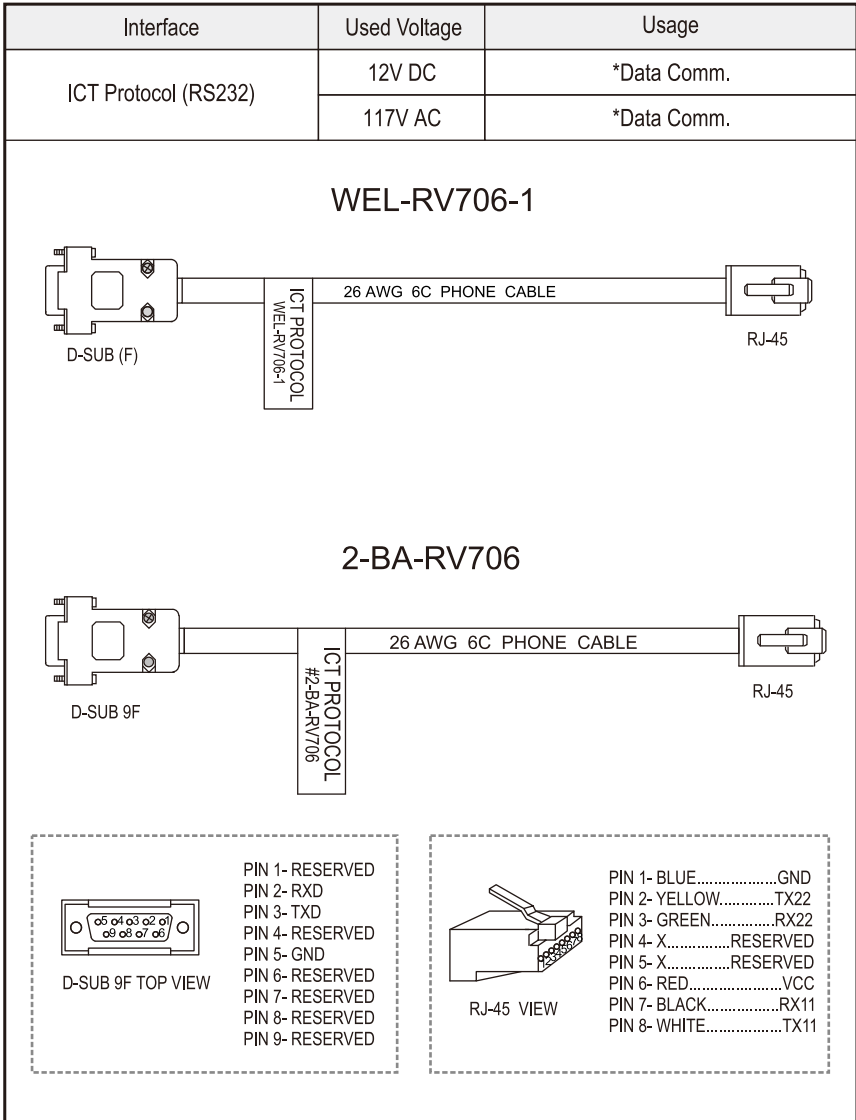

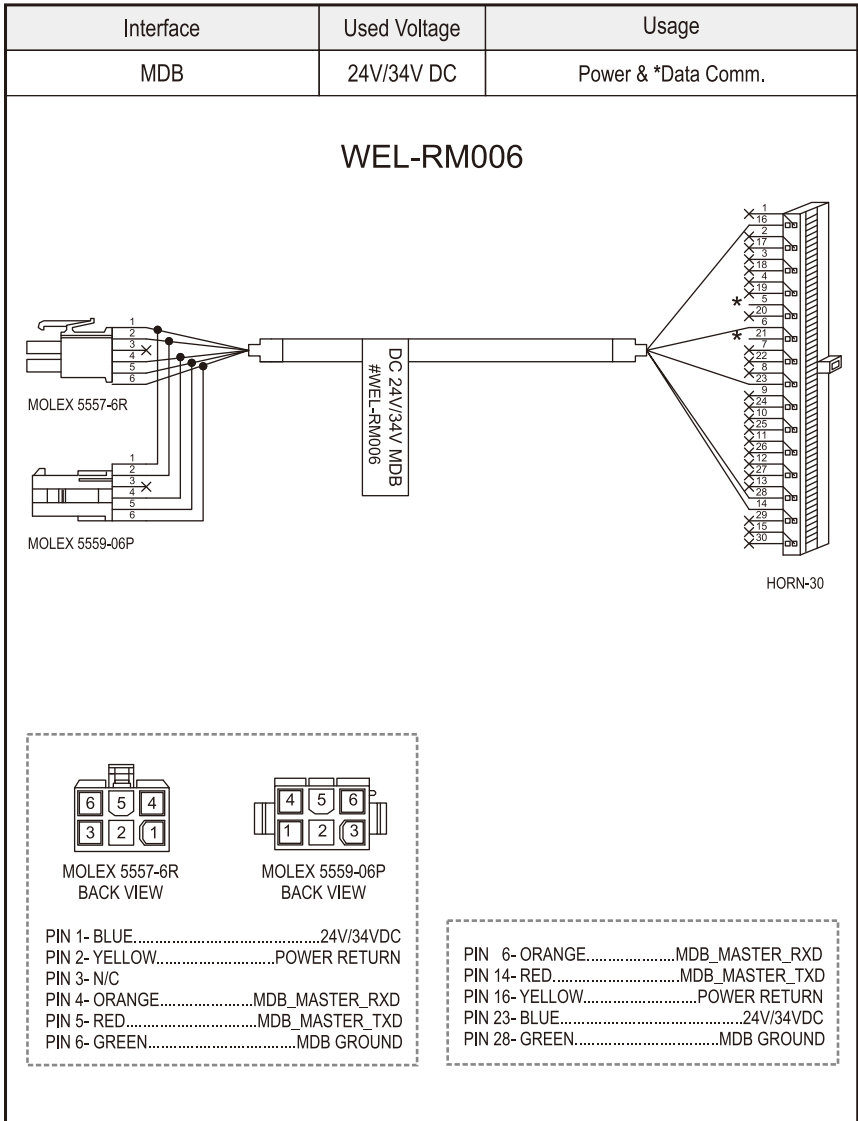

### 5-1-1. I/O Circuit

#### Pulse Interface.

5-1-1 FIG. 01

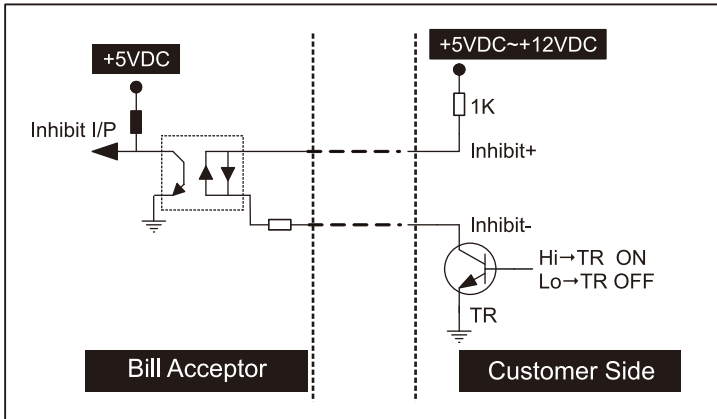
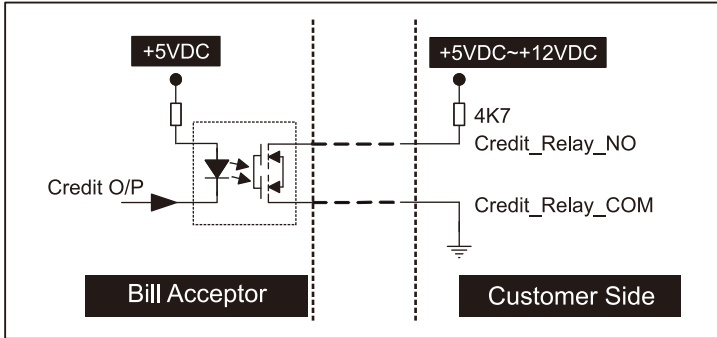

MDB Interface.

5-1-1 FIG. 02

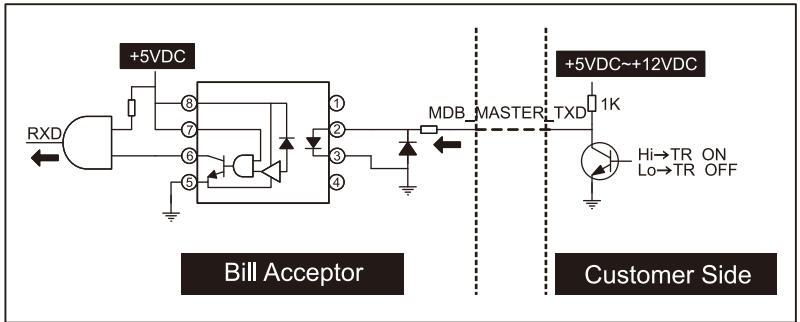
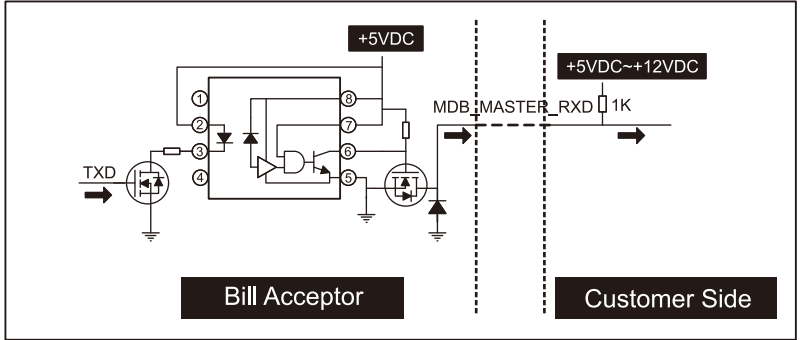

5V Enable Interface.

5-1-1 FIG. 03

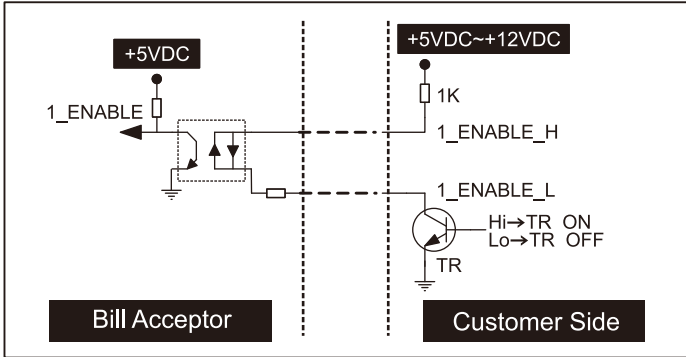

ICT-Protocol Interface.

5-1-1 FIG. 04

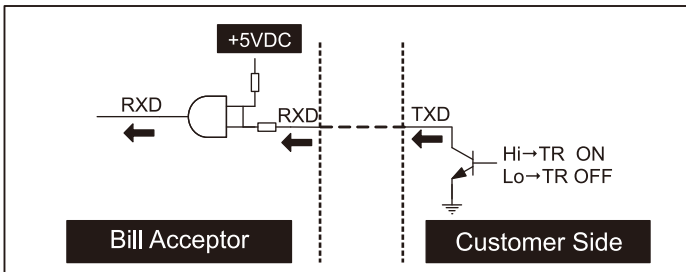
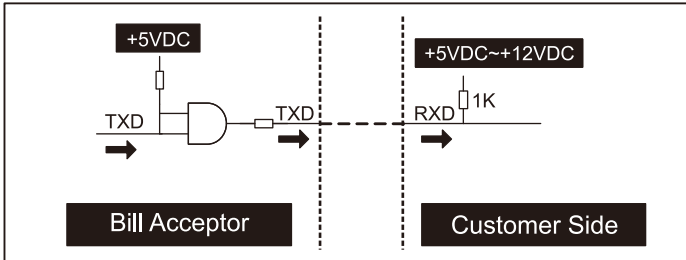

### 5-2. DIP Switch Setting

There are two serial DIP switches which are set on the side of A6E/V6E series(as FIG.01). According to different currencies which are used by users, DIP switch settings could be varied to fit users' needs. There is also a serial DIP switch on the base of the unit for inside interface settings (as FIG.02).

Please refer to "A6E/V6E series DIP Switch Setting Guide" in the package for more details.

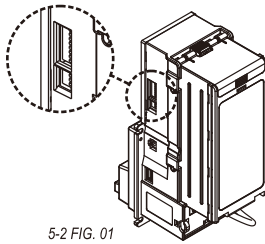

5-2 FIG. 01

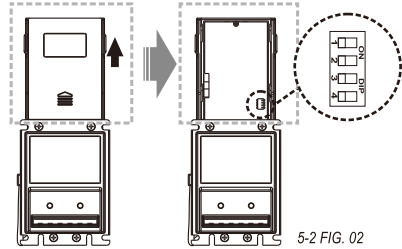

5-2 FIG. 02

### 5-3. Firmware Download and Upgrade

Step 1. Put the "A6E/V6Exxx.bin" file into your USB Pen Drive.



Step 2. Turn off A6E/V6E, plug the USB Pen Drive into the USB connector on the A6E/V6E and then turn on the A6E/V6E.

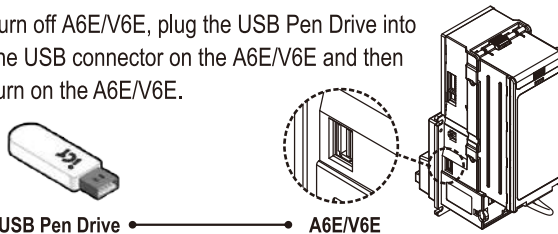

Step 3. The LED in the front side of bezel will flash twice, then remove the USB Pen Drive from A6E/V6E.

Step 4. Wait for about 30sec., Then A6E/V6E will automatically reset and standby for normal operation.

## 6. Maintenance

To make sure the bill acceptor always works smoothly, please clean the internal parts every two weeks to every two months.

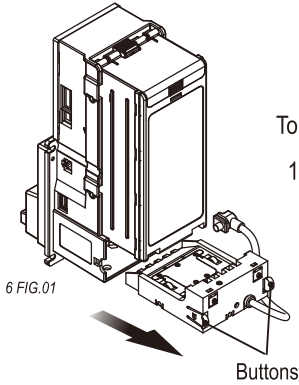

To clean the internal parts:

1. Press the buttons on the sides of bill path unit and pull the unit out.

2. Use a soft, dry cloth or towel to clean the bill path and sensors.

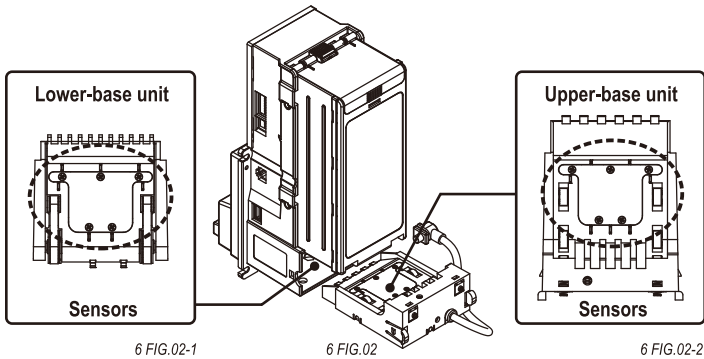

	<b>Maintenance Notice</b> <i>(Any improper maintenance will invalidate the warranty.)</i>	
	<b>Recommended</b>	<b>Mild, non-abrasive, soap water.</b>
<b>DO NOT USE</b>	<b>Organic solvent , Alcohol, Volatile liquid.</b>	

## 7. Troubleshooting

7 TABLE 01

LED	Status	Corrective Actions
Green	White Card Calibration.	Please calibrate with ICT white calibration card.

7 TABLE 02

LED Flashes (Green)	Status	Corrective Actions
1	Bill jammed.	Remove the bill box by sliding the top button and the bill path unit (as 7 FIG.01), and then remove the jammed bill.
2	Disable	Inspect for right DIP switch setting.
3	Recognition sensor error.	Inspect for foreign objects on sensor or bill path and clean.
3+2	Hook sensor error.	Inspect for foreign objects on security hook and clean.
4	A stringing attempt has detected.	Inspect the foreign objects on sensor or bill path and clean.
5	Bill box has been removed.	Replace the bill box.
6	Stacker error or stacker full.	Empty the bill box.
7	Motor error.	Inspect for foreign objects on bill path and clean.

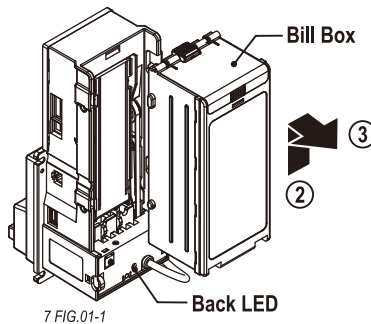
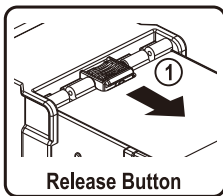

**If the error can not be solved after corrective actions or happen again, please contact ICT for technical support.**

**ict** Taiwan

**International Currency Technologies Corporation**

No.28, Ln. 15, Sec. 6, Mincuan E. Rd., Neihu Dist., Taipei City 114, Taiwan

[sales@ictgroup.com.tw](mailto:sales@ictgroup.com.tw) (For Sales)

[fae@ictgroup.com.tw](mailto:fae@ictgroup.com.tw) (For Customer Service)

Website: [www.ictgroup.com.tw](http://www.ictgroup.com.tw)

