



www.ictgroup.com.tw



Bill Acceptor

# TAO-A/V II

Series

Installation Guide

## **Use of Materials Limitations**

International Currency Technologies Corporation (ICT) all rights reserved.

All materials contained are the copyrighted property of ICT.

All trademarks, service marks, and trade names are proprietary to ICT.

ICT reserves the right at all times to disclose or to modify any information as ICT deems necessary to satisfy any applicable law, regulation, legal process or governmental request, or to edit, refuse to post or to remove any information or materials, in whole or in part, in ICT's sole discretion.

# Contents

<b>1. Introduction</b>	
1-1. Overview .....	2
1-2. Features .....	2
<b>2. Specifications</b> .....	3
<b>3. Packing List</b> .....	4
<b>4. Dimension</b> .....	5
<b>5. Installation</b>	
5-1. Harness Application .....	7
5-1-1. I/O Circuit .....	20
5-2. DIP Switch Setting .....	26
5-3. Software Download and Upgrade .....	26
5-3-1. USB Pen Drive Download .....	27
<b>6. Maintenance</b> .....	28
<b>7. Troubleshooting</b>	
7-1. Bezel LED Errors .....	29
7-2. Back LED Errors .....	30

## **1. Introduction**

### 1-1. Overview

TAO-A/V II series is a bill acceptor which features a lockable bill box for high-security with acceptance rate up to 96% or greater.

### 1-2. Features

- Four way bill insertion acceptance.
- Auto-calibrating.
- Win XP/Vista and Linux compatible USB interface available.
- Secure lockable and removable cashbox with 200, 500 or 1000 note capacity.
- Advanced water resistant design.
- Excellent resistant to humidity environment.
- Perfect for indoor and outdoor applications.
- Support update firmware using a USB flash drive.

## 2. Specifications

### *General*

<b>Acceptance Rate</b>	96 % or greater
<b>Bill Insertion</b>	Four way acceptable
<b>Transaction Speed</b>	Approx. 3 seconds to stack
<b>Interface</b>	TAO-A IIU: Pulse, 5V ENABLE, NISR ICT Protocol, Single Price. TAO-V IIU: Pulse, MDB, ICT Protocol.



**Installation: Indoor use only!!**

### *Electrical*

<b>Power Source</b>	TAO-A IIU: 12V DC (10.8V~13.2V DC) 117V AC (105.3V~128.7V AC)  TAO-V IIU: 12V DC (10.8V~13.2V DC) 24V AC (21.6V~26.4V AC) 34V DC (20V~42.5V DC)
<b>Power Consumption</b>	TAO-A IIU: 12V DC- Standby : 0.3A, 4W Operation: 0.9A, 11W Maximum: 2.6A, 32W  117V AC- Standby : 0.06A, 7W Operation: 0.12A, 15W Maximum: 0.4 A, 47W

<b>Power Consumption</b>	TAO-V IIU: 12V DC- Standby : 0.3A, 4W Operation: 0.8A, 10W Maximum: 2.5A, 30W
	24V AC- Standby : 0.2A, 5W Operation: 0.5A, 12W Maximum: 1.5A, 36W
	34V DC- Standby : 0.15A, 6W Operation: 0.4A, 14W Maximum: 1.35A, 46W

<b>Operation Environment</b>	Operation Temperature: 0°C~55°C Storage Temperature : -30°C~70°C Humidity: 30%~85% RH(no condensation)
------------------------------	--

### ***Mechanical***

<b>Bill Capacity</b>	TAO-A/V IIU-P2 : 200 bills TAO-A/V IIU-P5 : 500 bills TAO-A/V IIU-P10: 1000 bills
----------------------	---

<b>Weight</b>	TAO-A/V IIU-P2 : Approx. 1.3kg TAO-A/V IIU-P5 : Approx. 1.5kg TAO-A/V IIU-P10: Approx. 1.72kg
---------------	---

<b>Outline Dimension</b>	Refer to page. 5
--------------------------	------------------

<b>Bill Accepted Width</b>	62mm~66mm
----------------------------	-----------

## **3. Packing List**

<b>Main</b>	Bill Acceptor
<b>Accessory</b>	Harnesses: Refer to 5-1
	TAO-A/V II series Installation Guide
	TAO-A/V II series Switches Setting Guide
	Key for bill box
	Bezel Sticker

## 4. Dimension

TAO-A/V IIU-P2/ P5

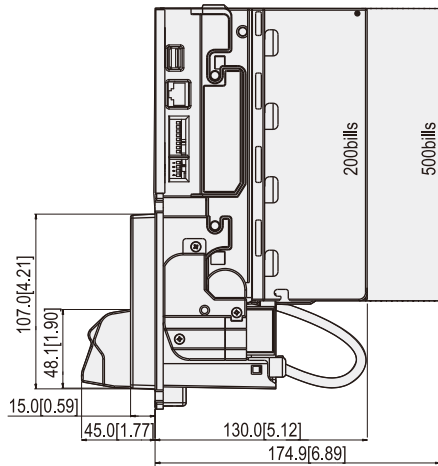
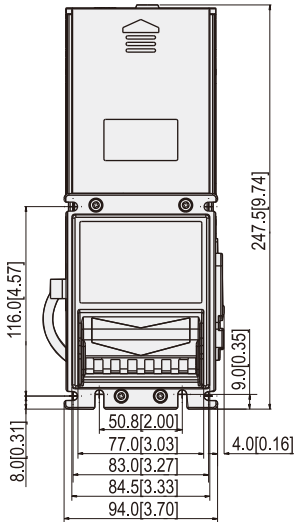
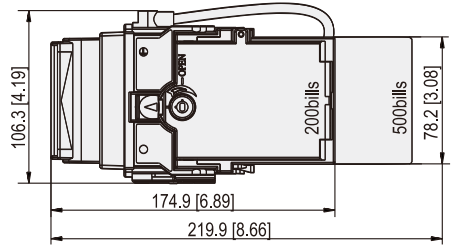

Unit : mm [inch]

4 FIG.01

TAO-A/V IIU-P10

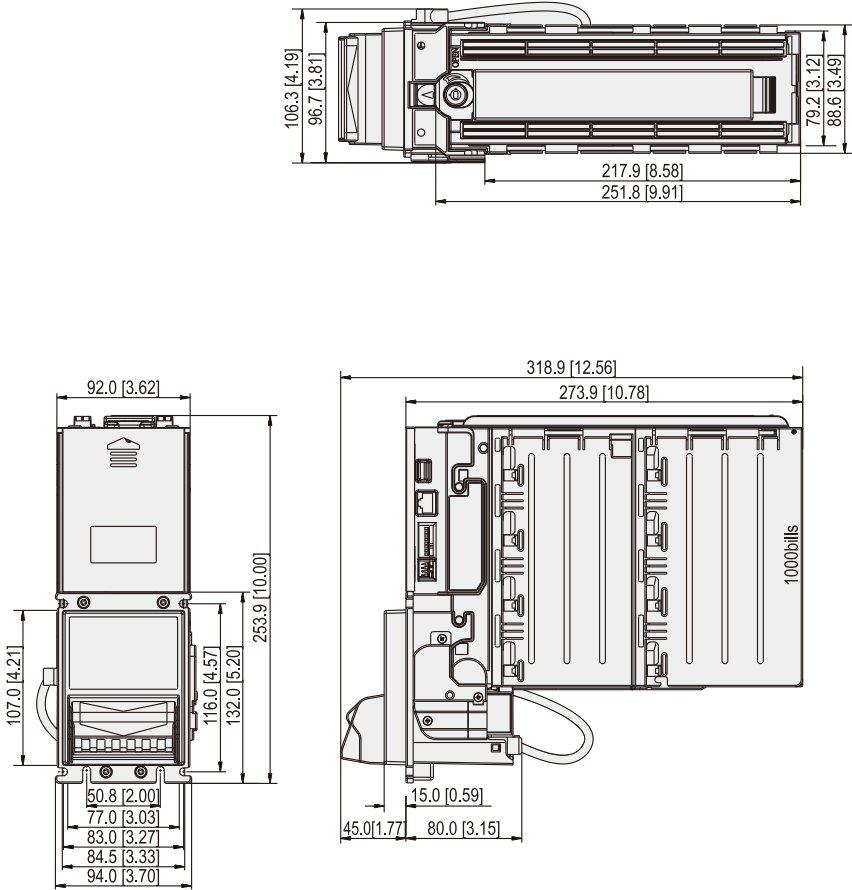

Unit : mm [inch]

4 FIG.02

## 5. Installation

### 5-1. Harness Application

5-1 TABLE 01

Model	Interface	Used Voltage	Usage	Harness	Page
TAO-A IIU	Standard Pulse	117V AC	Power & *Data Comm.	WEL-RM008	8
			Extension Wire	WEL-RM012	9
		12V DC	Power & *Data Comm.	WEL-RM007	10
			Extension Wire	CU-R961-1	11
	5V ENABLE	117V AC	Power & *Data Comm.	WEL-RM017	12
			Extension Wire	WEL-RM018	13
	RS232 for ICT Protocol	12V DC	Power	WEL-RM007	10
			Power Extension Wire	CU-R961-1	11
			*Data Comm.	WEL-RV706-1 or 2-BA-RV706	14
		117V AC	Power	WEL-RM008	8
			Power Extension Wire	WEL-RM012	9
			*Data Comm.	WEL-RV706-1 or 2-BA-RV706	14
	NISR	117V AC	Power & *Data Comm.	WEL-RM023	15
	Single Price	117V AC	Power & *Data Comm.	WEL-RM031	16
	USB Download	-	USB Extension Wire	WEL-RXBA31-2 (Optional)	19
TAO-V IIU	Standard Pulse	12V DC	Power & *Data Comm.	WEL-RV701	17
			Extension Wire	CU-R961-1	11
	MDB	34V DC	Power & *Data Comm.	WEL-RM006	18
	RS232 for ICT Protocol	12V DC	Power	WEL-RV701	17
			Power Extension Wire	CU-R961-1	11
			*Data Comm.	WEL-RV706-1 or 2-BA-RV706	14
	USB Download	-	USB Extension Wire	WEL-RXBA31-2	19

\* Data Comm. : Data Communication.

5-1 FIG.01

Interface	Used Voltage	Usage
Standard Pulse	117V AC	Power & *Data Comm.
RS232 for ICT Protocol	117V AC	Power

### WEL-RM008

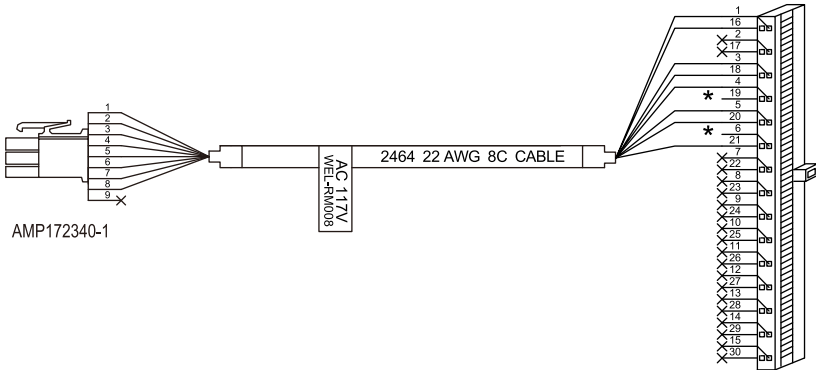

- PIN 1- YELLOW.....NEUTRAL INHIBIT
- PIN 2- RED.....NEUTRALE NABLE
- PIN 3- BROWN.....HOT ENABLE
- PIN 4- BLACK.....117VAC HOT(Power)
- PIN 5- GREEN.....Earth-Ground
- PIN 6- WHITE.....117VAC NEUTRAL(Power)
- PIN 7- BLUE.....CREDIT\_RELAY(N.O.)
- PIN 8- PURPLE.....CREDIT\_RELAY(Common)

- PIN 1- PURPLE.....CREDIT\_RELAY(Common)
- PIN 3- RED.....NEUTRALENABLE
- PIN 4- WHITE.....117VACNEUTRAL(Power)
- PIN 5- YELLOW.....NEUTRALINHIBIT
- PIN 16- BLUE.....CREDIT\_RELAY(N.O.)
- PIN 18- BROWN.....HOTENABLE
- PIN 20- BLACK.....117VACHOT(Power)
- PIN 21- GREEN.....EARTHGROUND

5-1 FIG.02

Interface	Used Voltage	Usage
Standard Pulse	117V AC	Extension Wire for WEL-RM008
RS232 for ICT Protocol	117V AC	Power Extension Wire for WEL-RM008

### WEL-RM012

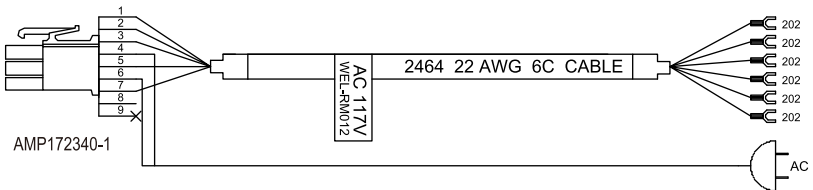

- PIN 1- YELLOW.....NEUTRAL INHIBIT+
- PIN 2- RED.....NEUTRAL INHIBIT-
- PIN 3- ORANGE.....HOT ENABLE
- PIN 4- BLACK.....117VAC HOT (Power)
- PIN 5- GREEN.....Earth - Ground
- PIN 6- BLACK.....117VAC NEUTRAL (Power)
- PIN 7- BLUE.....CREDIT\_RELAY (N.O.)
- PIN 8- PURPLE...CREDIT\_RELAY (Common)
- PIN 9- Reserved

- PURPLE.....CREDIT\_RELAY (Common)
- BLUE.....CREDIT\_RELAY (N.O.)
- GREEN.....Earth - Ground
- ORANGE.....HOT ENABLE
- RED.....NEUTRAL INHIBIT-
- YELLOW.....NEUARAL INHIBIT+

5-1 FIG.03

Interface	Used Voltage	Usage
Standard Pulse	12V DC	Power & *Data Comm.
RS232 for ICT Protocol	12V DC	Power

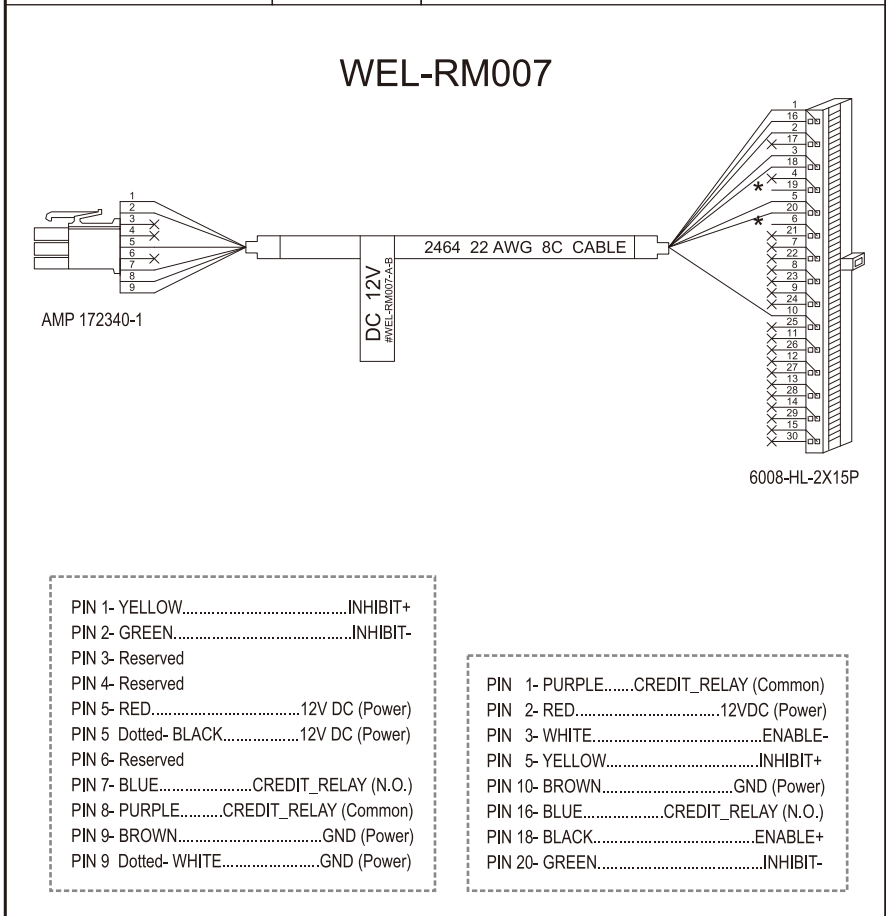

5-1 FIG.04

Interface	Used Voltage	Usage
Standard Pulse	12V DC	Extension Wire for WEL-RM007
Standard Pulse	12V DC	Extension Wire for WEL-RV701
RS232 for ICT Protocol	12V DC	Power Extension Wire for WEL-RM007
RS232 for ICT Protocol	12V DC	Power Extension Wire for WEL-RV701

### CU-R961-1

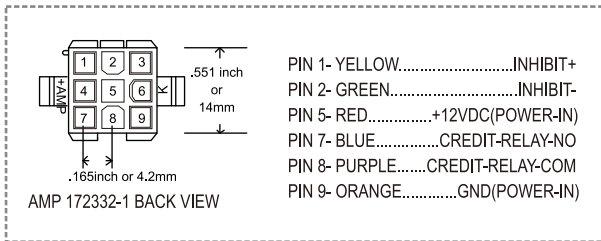
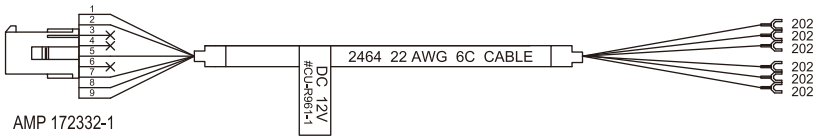

Interface	Used Voltage	Usage
5V ENABLE	117V AC	Power & *Data Comm.

### WEL-RM017

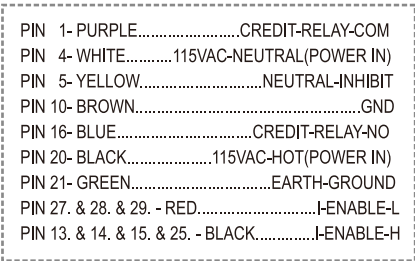
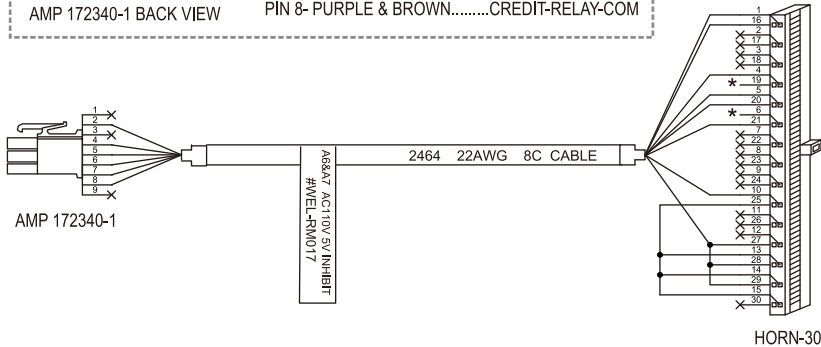
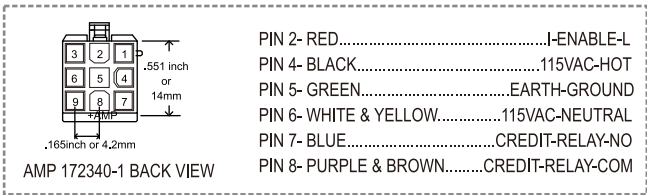

5-1 FIG.06

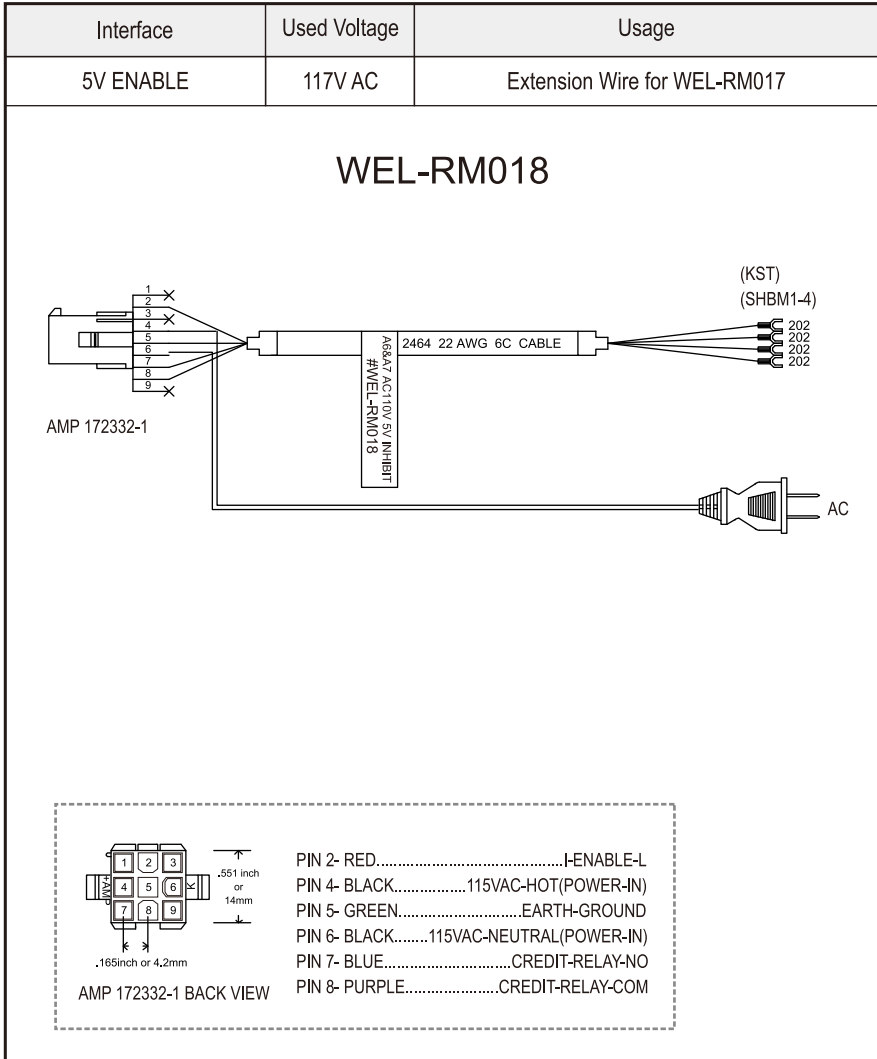

5-1 FIG.07

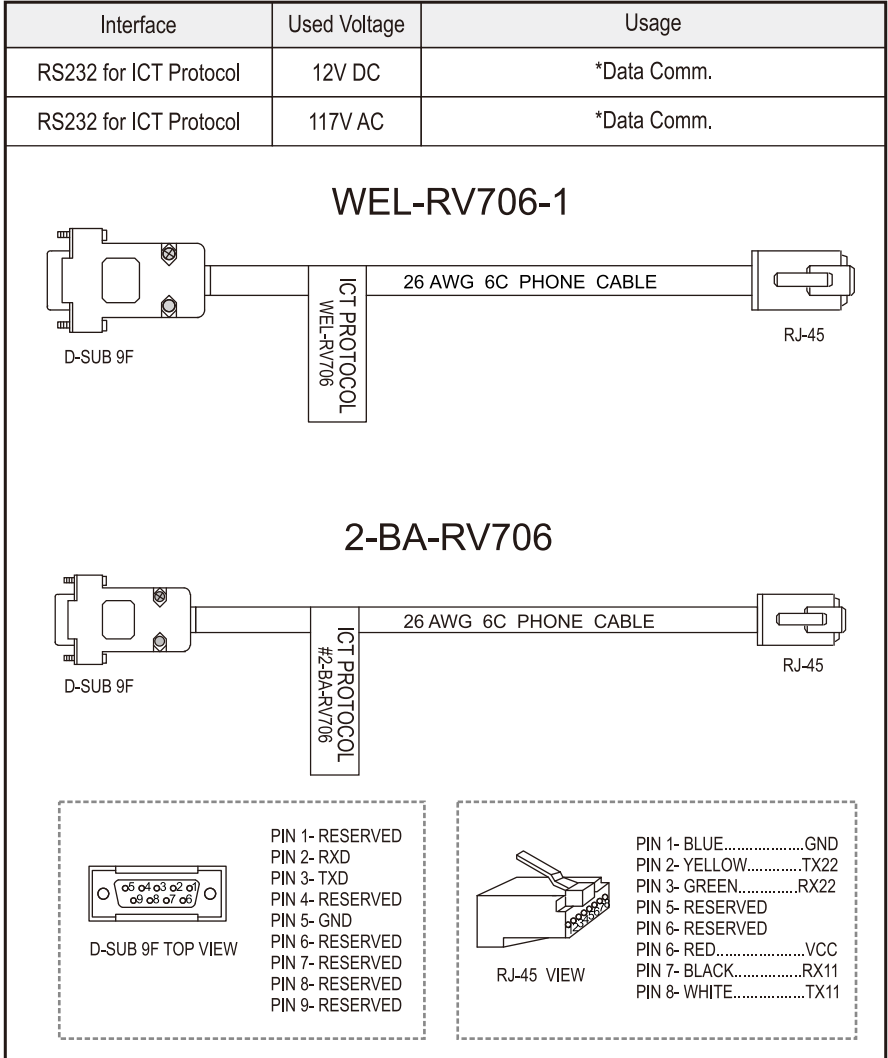

5-1 FIG.08

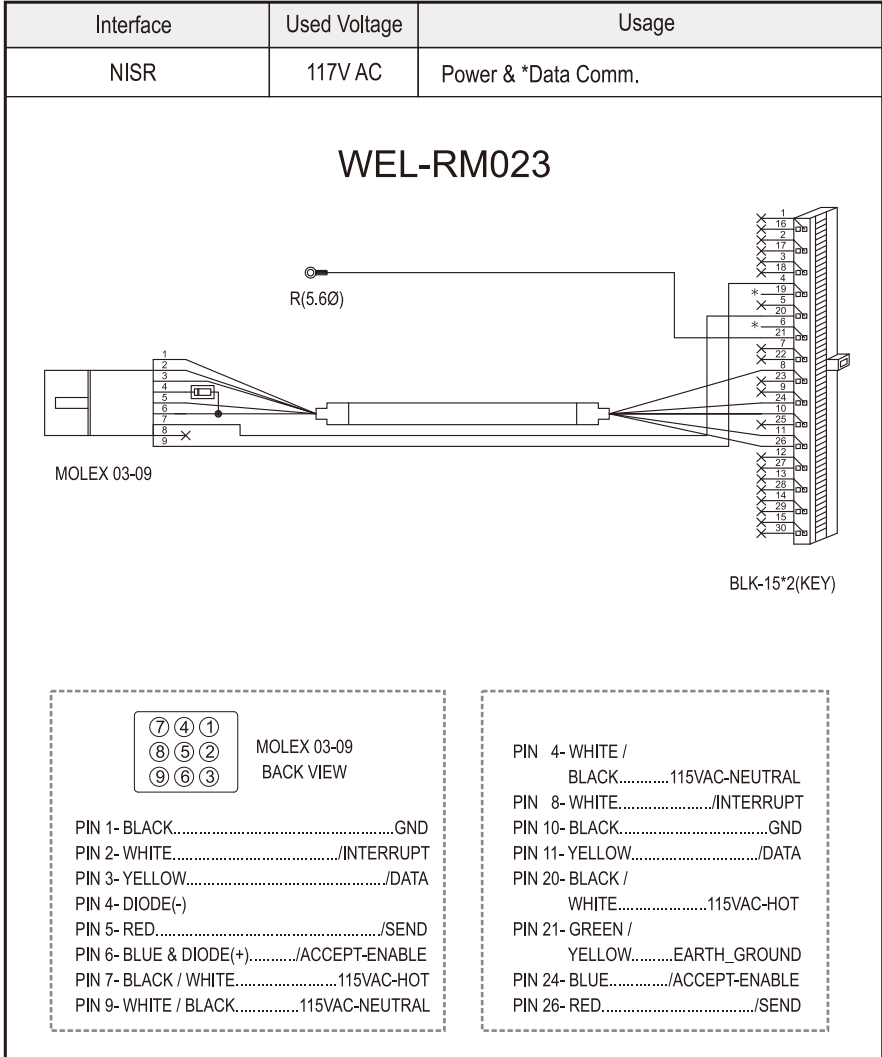

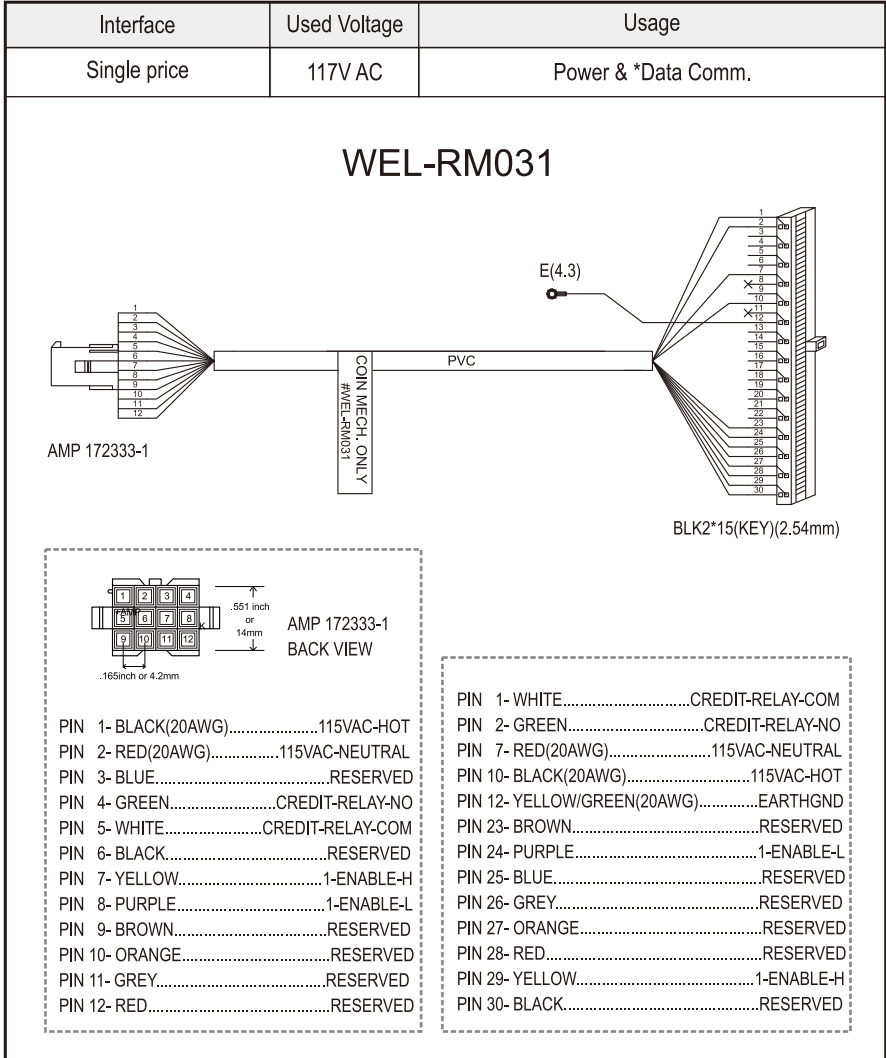

5-1 FIG.10

Interface	Used Voltage	Usage
Standard Pulse	12V DC	Power & *Data Comm.
RS232 for ICT Protocol	12V DC	*Data Comm.

## WEL-RV701

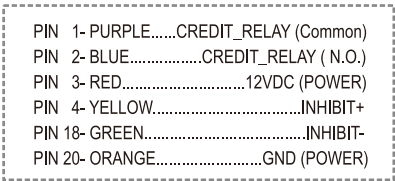
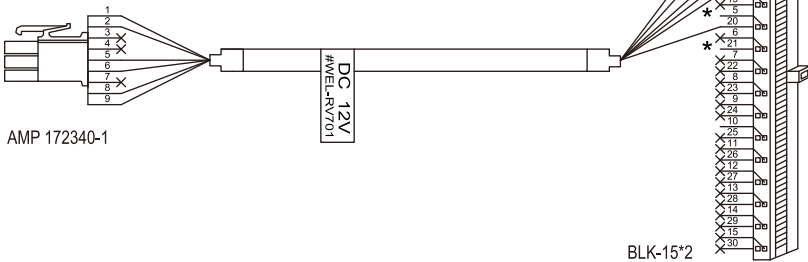
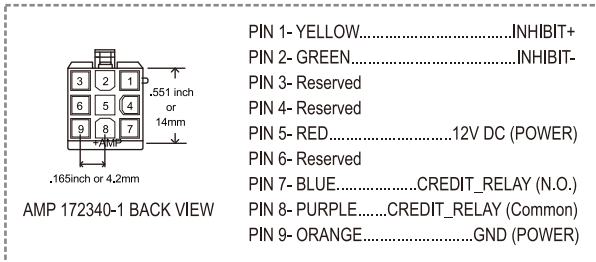

5-1 FIG.11

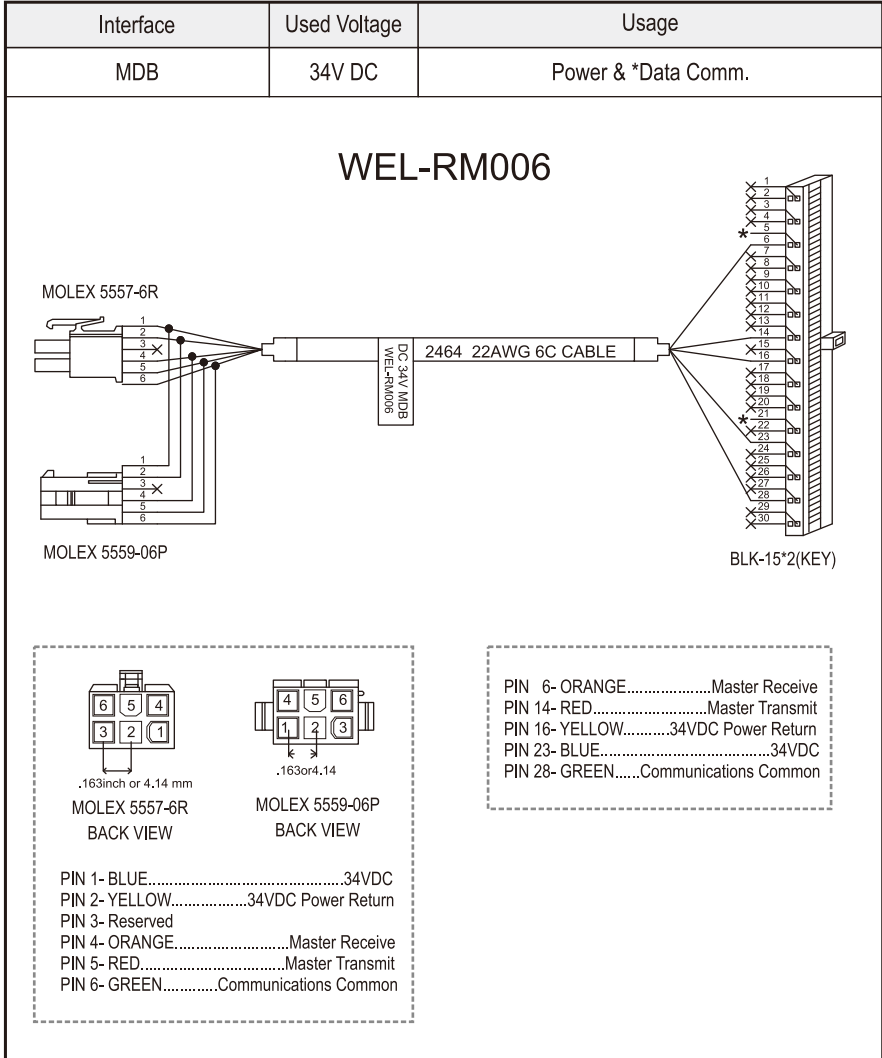

5-1 FIG.12

Interface	Used Voltage	Usage
USB Download	-	USB Extension Wire

## WEL-RXBA31-2





PIN 1- RED.....VCC  
 PIN 2- WHITE.....D-  
 PIN 3- GREEN.....D+  
 PIN 4- BLACK.....GND



PIN 1- RED.....VCC  
 PIN 2- WHITE.....D-  
 PIN 3- GREEN.....D+  
 PIN 4- BLACK.....GND

5-1-1. I/O Circuit  
Pulse Interface.

5-1-1 FIG.01

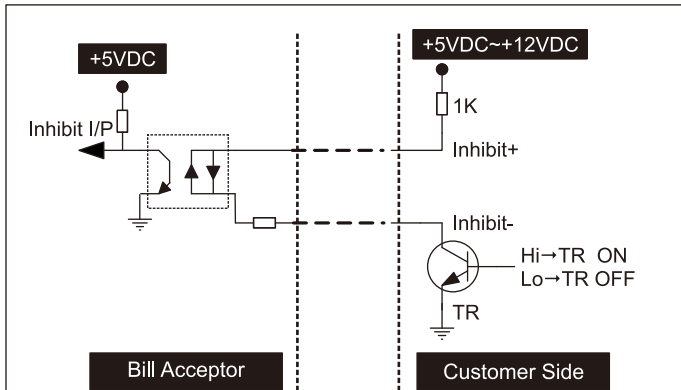
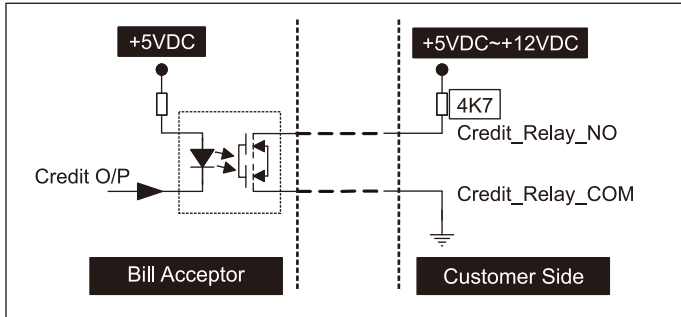

BA Status	*DIP SW Setting	Control Signal
Inhibit	Low	Low
	High	High
Enable	Low	High
	High	Low

\*Note: Please refer to DIP Switch Setting Guide for detail.

5V Enable Interface-1

5-1-1 FIG.02

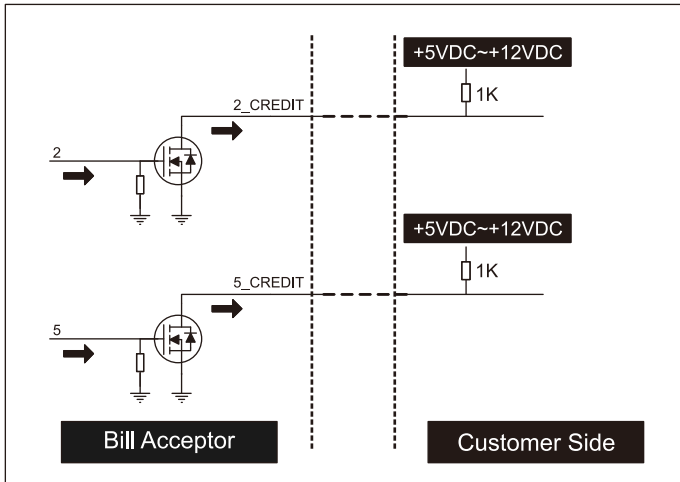

5V Enable Interface-2

5-1-1 FIG.02-1

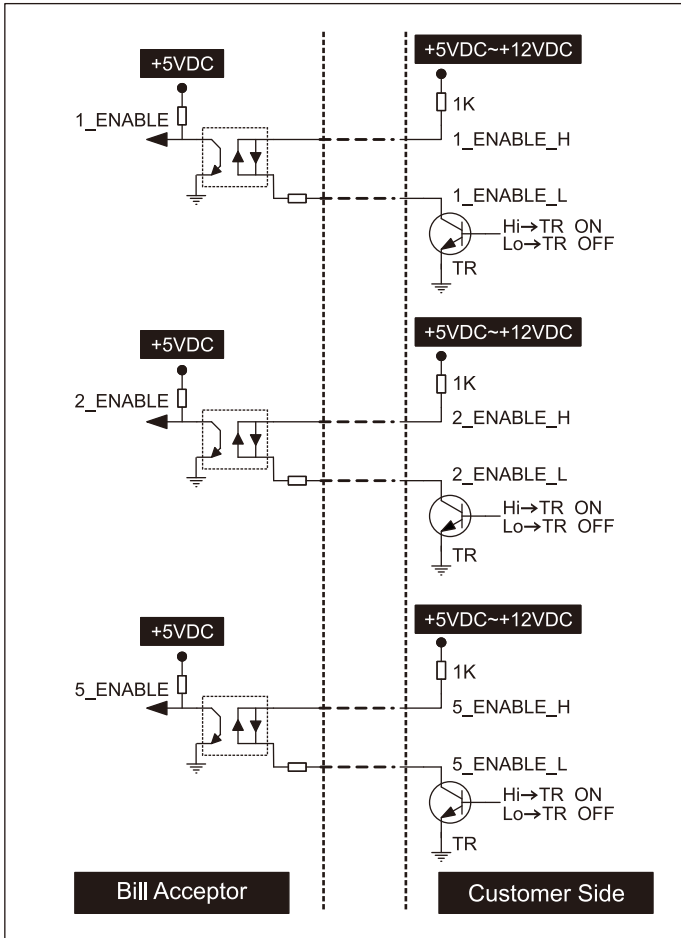

ICT Protocol Interface.

5-1-1 FIG.03

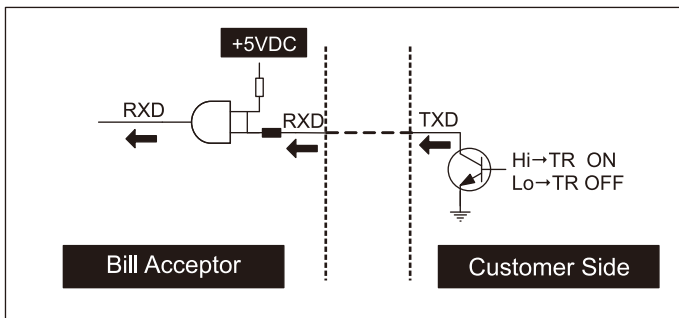
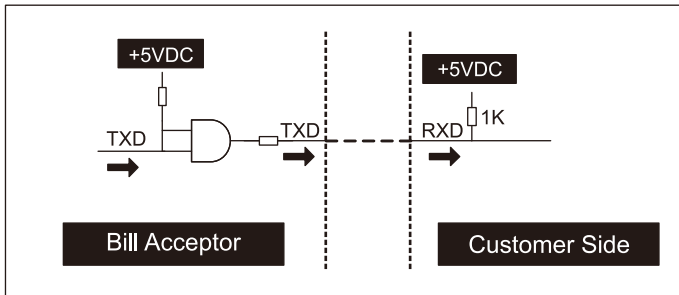

NISR Interface.

5-1-1 FIG.04

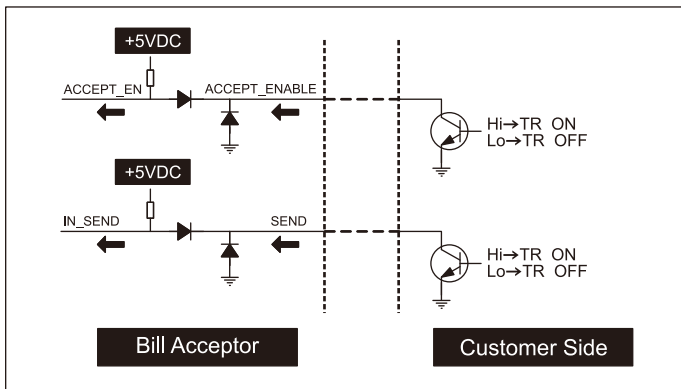
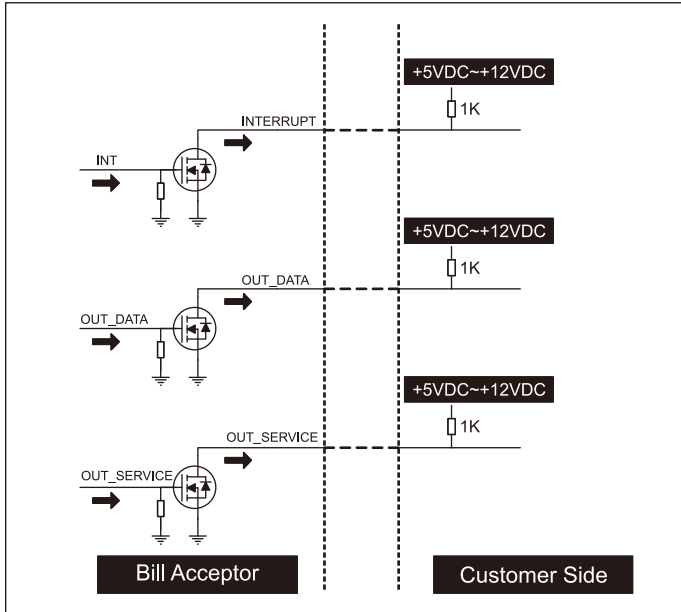

MDB Interface.

5-1-1 FIG.05

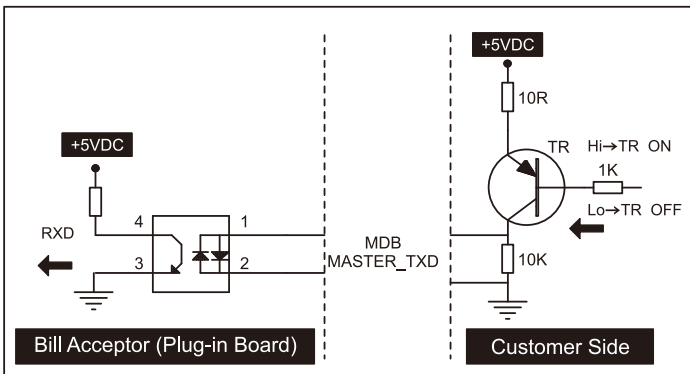
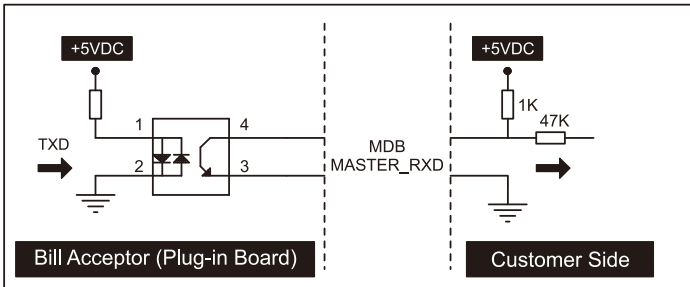

### 5-2. DIP Switch Setting

There are two serial DIP switches which are located on the side of TAO-A/V IIU (as FIG.01). According to different currencies which are used by users, DIP switch settings could be varied to fit users' needs. Besides, there's also a serial DIP switches on CPU board inside of TAO-A/V IIU for interface settings (as FIG.02).

Please refer to "TAO-A/V series DIP Switch Setting Guide" in the package for more details.

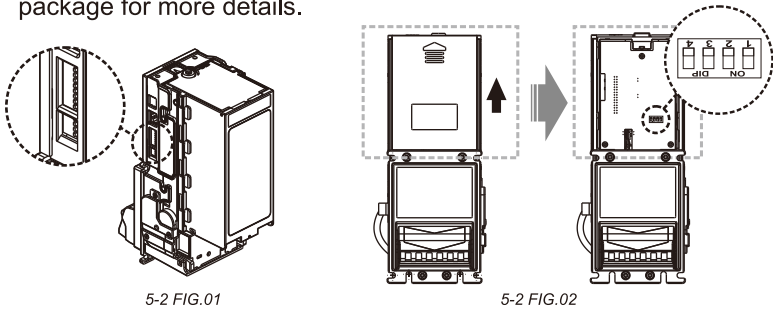

### 5-3. Software Download and Upgrade

To download and upgrade the software to TAO-A/V IIU, the programmer (FP-004) is needed. Please contact ICT to purchase FP-004 and refer to FP-004 user guide for software download and upgrade information.

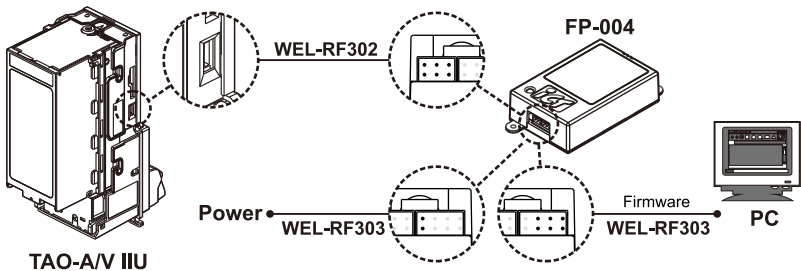

Power must be applied to Bill Acceptor **after** connecting.

### 5-3-1. USB Pen Drive Download

1. Plug in the USB Pen Drive's (with new firmware in the root file directory) in to the USB Socket on the bill acceptor.
2. Reboot the power of the bill acceptor.
3. The update process will automatically begin and the status LED indicates the different update progress showing in the following chart.

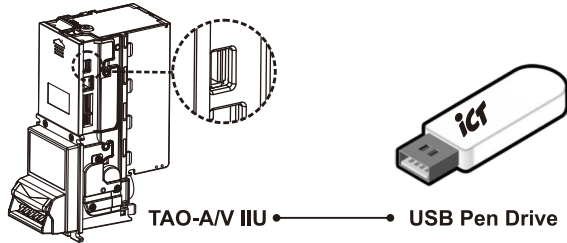

#### 4. The location of status LED

LED Indicator	Status
Flashing (Interval: 100 ms)	Update in progress
Flashing twice (Interval: 1sec)	Update successful
No light	1. Update fail 2. No firmware found in the Flash Drive

**Note:**

1. Do not remove the USB Pen Drive during the update process.
2. If the USB Pen Drive contains more than one firmware, the device will use the last modified date as the firmware to be transfer to the bill acceptor.
3. Please remove the USB Pen Drive when the upgrade has finished.

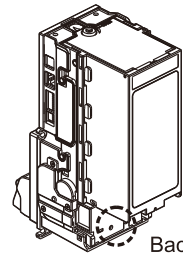

Back LED  
5-3-1 FIG.01

## 6. Maintenance

To make sure the bill acceptor always works smoothly, please clean the internal parts regularly.

To clean the internal parts:

1. Press the buttons on the sides of bill path and pull the unit out.

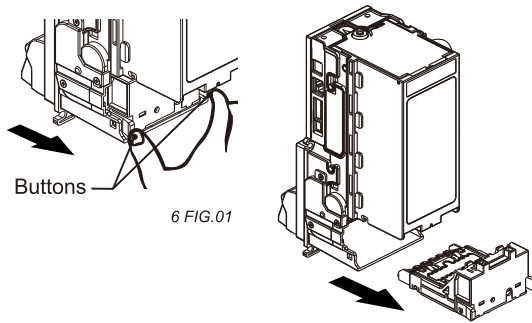

2. Use a soft, dry cloth, or towel to clean the bill path and sensors.

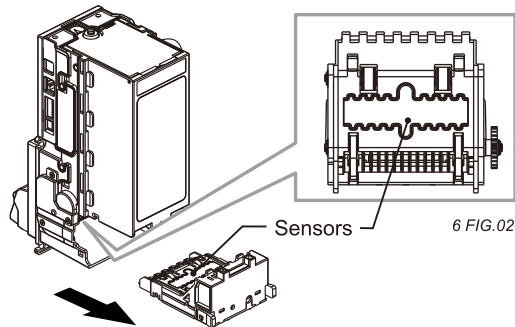

	<b>Maintenance Notice</b>	
	<i>(Any improper maintenance will result in invalid warranty.)</i>	
<b>Recommended</b>	Mild, non-abrasive, soap water.	
<b>DO NOT USE</b>	Organic solvent , Alcohol, Volatile liquid.	

## 7. Troubleshooting

### 7-1. Bezel LED Errors

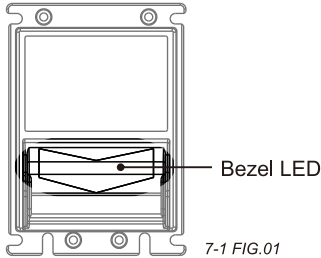

7-1 TABLE 01

LED Flashes		Status	Correct Actions
Red	Green		
	<b>1</b>	White Card Calibration.	Please calibrate with ICT white calibration card.
<b>1</b>		Bill jammed.	Remove the bill box by sliding the top button and the bill path (refer to page 32), and then remove the jammed bill.
<b>2</b>		Disable.	Inspect the right DIP switch setting.
<b>3</b>		Recognition sensor module error.	Inspect the foreign objects on sensor or bill path and clean.
<b>3+2</b>		Hook sensor error.	Inspect the foreign objects on security hook and clean.
<b>3+4</b>		Out sensor error. (as 7-2 FIG.02)	Inspect the foreign objects on sensor or bill path and clean.
<b>4</b>		Anti-string sensor error or a stringing attempt has detected.	Inspect the foreign objects on sensor or bill path and clean.
<b>5</b>		Bill box has been removed.	Replace the bill box.
<b>6</b>		Stacker error or stacker full.	Empty the bill box.
<b>7</b>		Motor error.	Inspect the foreign objects on bill path and clean.

## 7-2. Back LED Errors

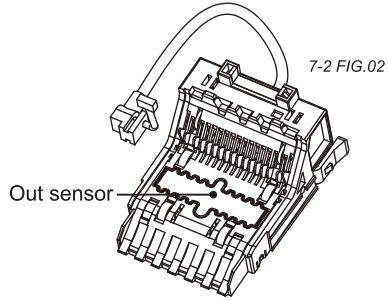
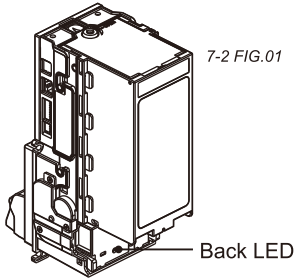

7-2 TABLE 01

LED Flashes	Status	Corrective Actions
Green		
1	White Card Calibration.	Please calibrate with ICT white calibration card.
1	Bill jammed.	Remove the bill box by sliding the top button and the bill path (refer to page 32), and then remove the jammed bill.
2	Disable.	Inspect the right DIP switch setting.
3	Recognition sensor module error.	Inspect the foreign objects on sensor or bill path and clean.
3+2	Hook sensor error.	Inspect the foreign objects on security hook and clean.
3+4	Out sensor error. (as 7-2 FIG.02)	Inspect the foreign objects on sensor or bill path and clean.
4	Anti-string sensor error or a stringing attempt has detected.	Inspect the foreign objects on sensor or bill path and clean.
5	Bill box has been removed.	Replace the bill box.
6	Stacker error or stacker full.	Empty the bill box.
7	Motor error.	Inspect the foreign objects on bill path and clean.



**If the error can not be solved after corrective actions or happen again, please contact ICT for technical support.**

◆ TAO-A/V IIU-P2/P5

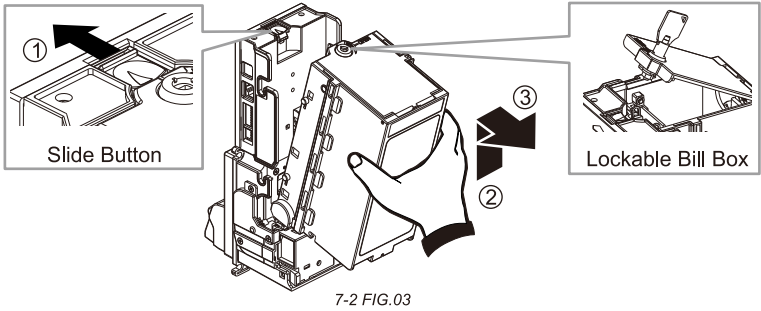

◆ TAO-A/V IIU-P10

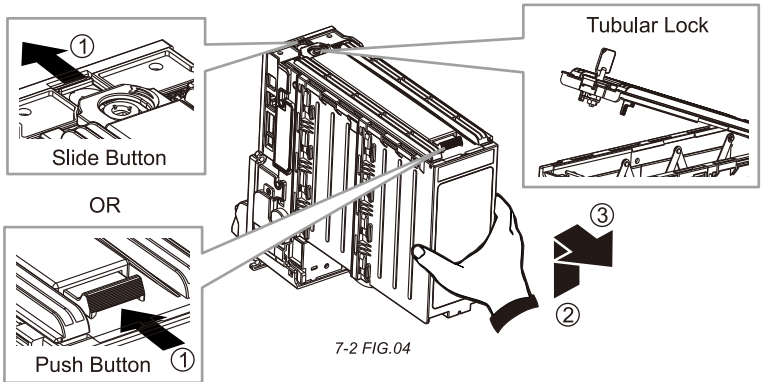



***ict*** Taiwan

**International Currency Technologies Corporation**

No.28, Ln. 15, Sec. 6, Minquan E. Rd., Neihu Dist., Taipei City 114, Taiwan

[sales@ictgroup.com.tw](mailto:sales@ictgroup.com.tw) (For Sales)

[fae@ictgroup.com.tw](mailto:fae@ictgroup.com.tw) (For Customer Service)

Website: [www.ictgroup.com.tw](http://www.ictgroup.com.tw)

